



RFID



FORS

GENERAL
CATALOGUE

INNOVATIVE
ANTI-THEFT
SOLUTIONS



TABLE OF CONTENTS

PAGE 6 EAS SOLUTIONS

• General presentation	08
• FORSbox and FORScloud	10
• Antennas	12
• Options and tag removers	20
• Gates and guidance	26

PAGE 28 RFID

• Why choose our RFID solutions	30
• Application systems	32
• Global offer	36

PAGE 38 EAS ACCESSORIES

• Labels	40
• Forstag solutions	42
• Anti-theft tags and retail accessories	44
• Anti-theft devices for food and beverage	50
• Spiders and alarm-equipped anti-theft devices	56
• Spindle protection	58
• Tag removers	59

PAGE 60 SAFE CASES

• Options for alarms and case customization	62
• Video games and CDs	64
• IT and smart objects	70
• TV and audio accessories	76
• Telecom and GPS	78
• Batteries	79
• Beauty and hygiene	80
• Reference table and life-size guide	84

PAGE 88 TOUCH DISPLAY AND MONITOR DISPLAYS

• Alarme 2	90
• Loop 2 and Splitter 2	96
• Watch	97
• Mechanical protections	99
• Listening stations	100



ABOUT US



Fors France is a French company specialized in manufacturing and selling anti-theft solutions that effectively prevent and stop inventory losses.

We are present in 30 countries.

Thanks to a close collaboration with mass-market retailers and specialized shops established over 35 years, Fors France is a key specialist of all in-store shoplifting related issues.

We offer the widest range of anti-theft antennas on the market, with different levels of protection.

We also develop security accessories designed for self-service.

In order to keep our competitive edge and our pole position on the market in terms of innovation, we give the utmost importance to the protection of our products through patenting, models and drawings registration.

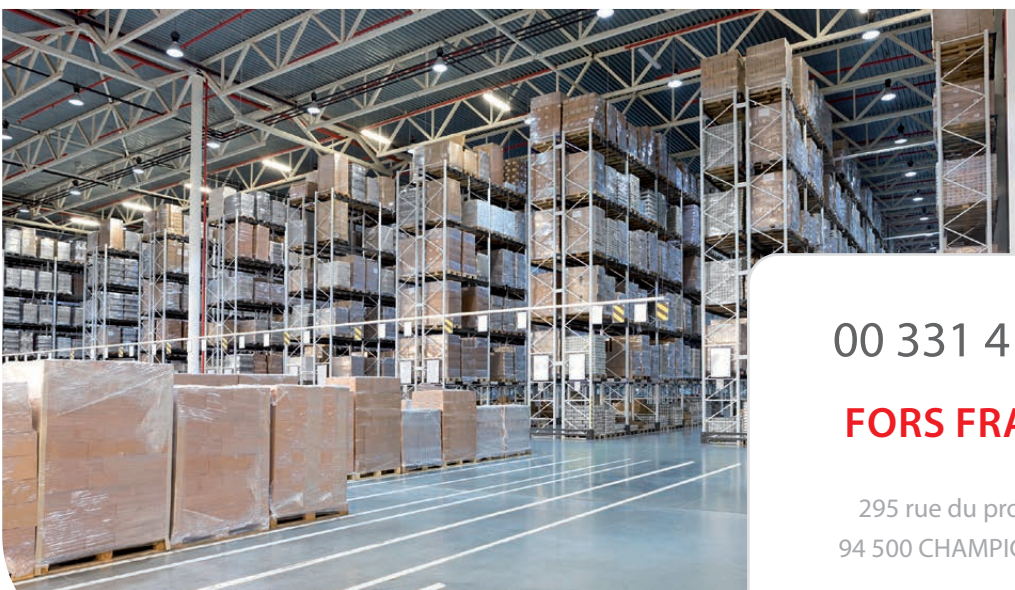

3 000 m² of warehouse located in and around Paris.

00 331 4177 6200

FORS FRANCE SAS

295 rue du professeur Milliez
94 500 CHAMPIGNY SUR MARNE

Since 1984



Anti-Theft Solutions



Reactivity and flexibility are key words at Fors, as they have been from the start.

Knowledge of the market : We have expert knowledge in the security and anti-theft domains.

Robustness : We create durable and robust products.

Strengths : We are excellent at plastic processing, metallurgy, IT, electronics, and design.

Worldwide : We are present in more than 30 countries and are developing fast in emerging countries.

French manufacture : Our safe cases, antennas and listening stations are manufactured in France.



100% french compagny
since 1984



OUR PATENTS

Constant innovation: Thanks to our innovative and customer-oriented mindset, we will create the perfect-fit product that meets your requirements.

At the forefront of technology from conception to development, we create tomorrow's products for you.

14 patents
Fors



THE FORS TEAM

Our sales team partners with you: We will support you and guide you with the mass market retailer brands throughout the procurement process, on both the technical and financial aspects.

Our sales team listens to you: your feedback is precious to our Research and Development department team in their design process.

Reactivity | Flexibility | Partnership



OUR CREDENTIALS



Fors has built a solid reputation of reliability, constant innovation and quality French manufacturing throughout the years, for our flagship products such as the safe cases, the antennas and all of

our products range. We are proud to commit to these values and the work ethic they represent in today's market.

EAS SOLUTIONS

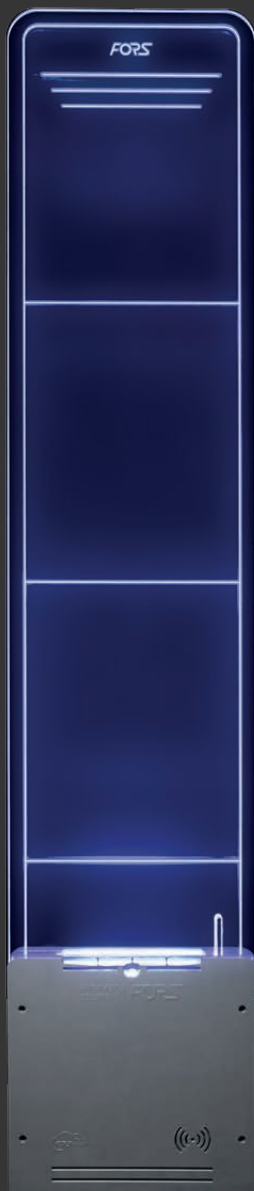

DETECTION ANTENNA

RF Orchestra Plus

- DSP with SmartPulse function
- Automatic interferences analysis
- Excellent detection
- Polyvalent antenna
- Design
- Durable and stable performances
- Ultra Slim
- Online maintenance (optional)
- People counter (optional)
- Automatic analysis (optional)
- Beeper (optional)
- Closed checkout passage (optional)
- Backlighting (optional)
- Dry contact (optional)

More information p.12



- General presentation 08
- EAS and FORScloud solutions 10
- Detection antennas :
 - Radio Frequency (RF) Mono 12
 - Radio Frequency (RF) Duo (Rx-Tx) 14
 - Magneto-acoustic (AM) 16
 - Metals and magnet detectors 18
- Options :
 - Deactivators / Detectors 20
 - Video protection 23
 - People counter 24
- Guidance and security gates 26





EAS SOLUTIONS

GENERAL PRESENTATION

ANTENNAS

For over 30 years, Fors France has been considered a leader in in-store anti-theft security.

Thanks to their knowledge of the products on the ground, our team is available to support you in your projects.

Always thriving for excellence, our RF and AM antennas include the latest generation of DSP so as to protect your products as well as possible.

Almost 3 500 stores have already been equipped with the Fors antennas in France and around the world.

RF INSTALLATION EXAMPLES FOR CHECKOUT (SUPERMARKET)

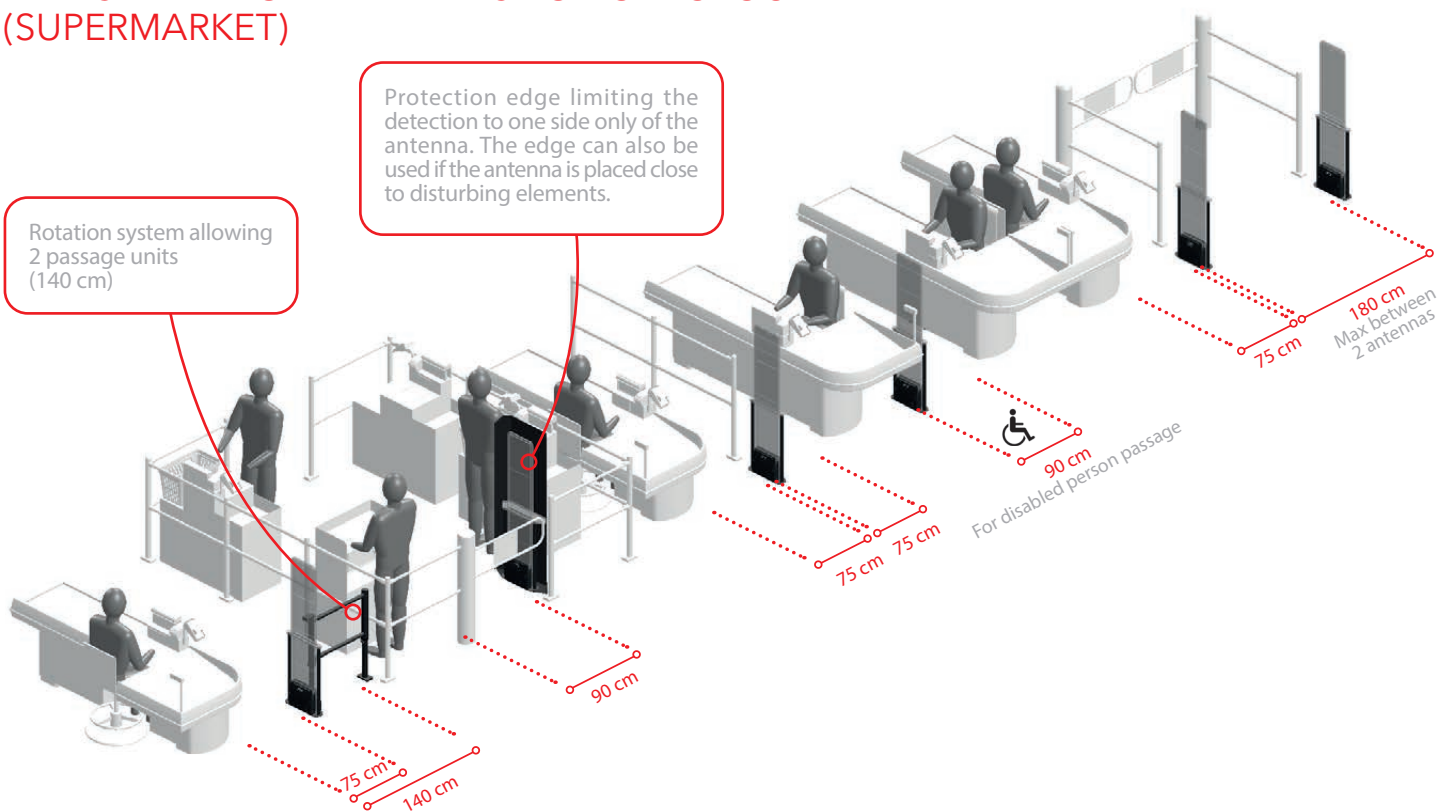

Installation recommendations



Leave **20 cm** between the antenna and the guidance bar.

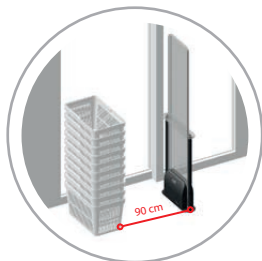

Leave **90 cm** between the antenna and the protected baskets.

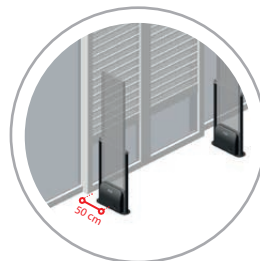

Leave **50 cm** between the antenna and the automatic door.

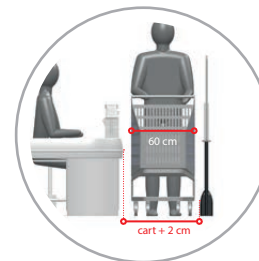

Place the antenna to allow enough space for a cart.



EAS SOLUTIONS

GENERAL PRESENTATION



ANTENNAS DETECTION

For the RF and AM technologies, there are 2 types of antennas :

- **DUO antennas :**

They work in pairs and the detection field is solely between the antennas.

- **MONO antennas :**

They can be installed as standalone or in series. They detect on either side of the antenna.

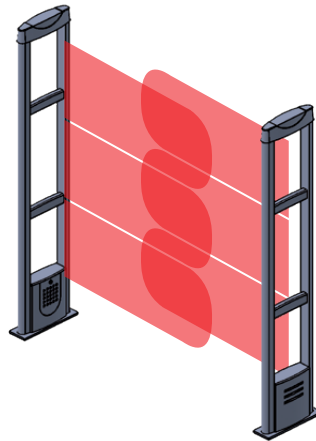

Duo antennas

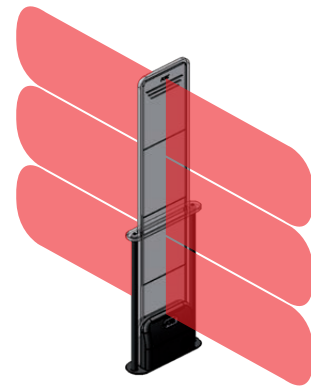

Mono antenna

For all your projects

Contact our sales department at :

00 331 4177 6200

and by email : contact.commercial@fors.fr

Our team will study the best set-up with you to guarantee maximum security for your products.



Our wide network of certified technicians ensures your installations maintenance.



Installation in mainland France.



EAS SOLUTIONS

FORSBOX SOLUTION FOR ORCHESTRA ANTENNAS

FORSBOX

Interconnected to the antennas, the FORSbox allows them to be connected to the Internet.

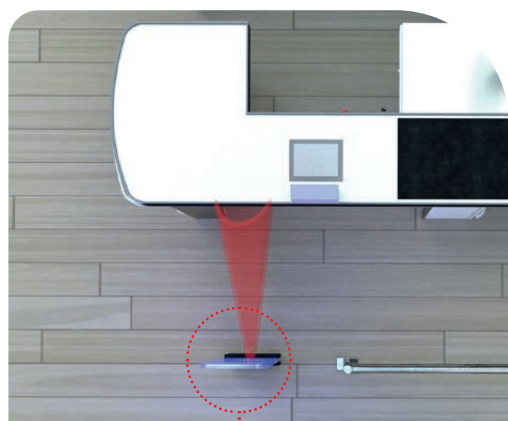

PEOPLE COUNTER

The people count device offers a measurement of the people flow at the accesses it is set up in. See p. 24 for more information.

CLOSED CHECKOUT PASSAGE & ALARM

The closed checkout passage allows for the detection of clients when the checkout is closed. The antenna's red light then goes on.

The closed checkout passage alarm is activated manually by the cashier when they close.

EAS ANTENNA

The connected Orchestra antenna allows access to FORScloud services (see p.13)

BACKLIGHTING

Permanent blue light effect and red alarm.

CALL BUTTON

It allows the cashier to call security in case of issue.

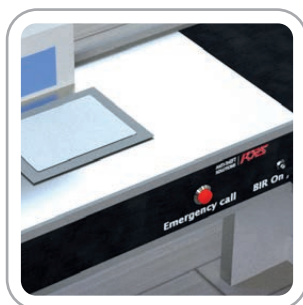

BEEPER

Intended for the security staff, the beeper allows to receive all the alarms to be able to react fast (closed checkout alarm, badge detection, cashier call...)





EAS SOLUTIONS

FORSCLOUD SOLUTION FOR ORCHESTRA ANTENNAS

FORSCLOUD

The SmartPulse technology guarantees quality and reliability of the material in time.

Our FORScLoud solution embeds online maintenance and makes feedback easier for store managers.

MAINTENANCE

Online Internet maintenance allows our technicians to intervene on all our antennas' set-up, so as to make our customer service more efficient.

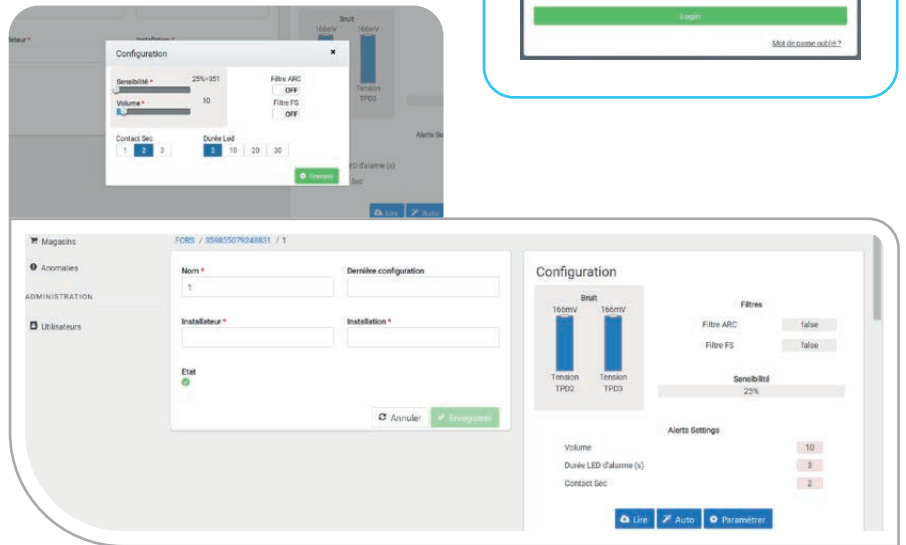
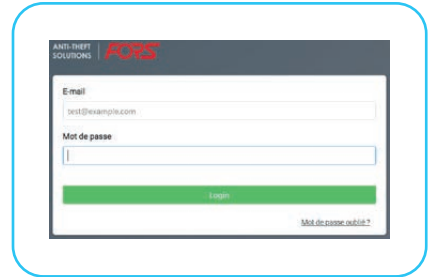

REPORTING ANALYSIS

The reporting and analysis offer you a better EAS follow-up of your store no matter where it is in the world.

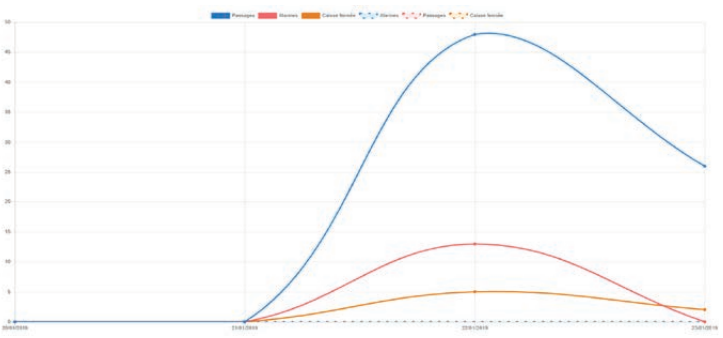

FORS SERVERS

Our servers allow you to access in real time the data and feedback provided by our antennas on the ground.

ID	Nom	Nombre	Statut	Description	Date
41813	Passage	0			Tue Jan 22 2019 10:25:32 GMT+01:00
41814	Passage	0			Tue Jan 22 2019 10:25:04 GMT+01:00
41813	Health configuration porteur	1		ESPT1-15 ESPT02-4- Filtrage ABC, Contact Sec, Durée Led-3	Tue Jan 22 2019 10:17:12 GMT+01:00
41811	Passage	1			Tue Jan 22 2019 10:04:49 GMT+01:00
41810	Alarme	1		2019-01-22 09:59:12 +05	Tue Jan 22 2019 10:04:32 GMT+01:00
41809	Alarme	1		2019-01-22 09:52:46 +05	Tue Jan 22 2019 10:02:46 GMT+01:00
41808	Passage	1			Tue Jan 22 2019 10:02:44 GMT+01:00
41807	Alarme	1		2019-01-22 09:52:20 +05	Tue Jan 22 2019 10:02:20 GMT+01:00
41806	Passage	10			Tue Jan 22 2019 10:02:42 GMT+01:00
41805	Alarme	1		2019-01-22 09:50:24 +05	Tue Jan 22 2019 10:02:33 GMT+01:00
41804	Passage caisse fermée	1			Tue Jan 22 2019 10:02:28 GMT+01:00
41803	Passage caisse fermée	1			Tue Jan 22 2019 10:02:23 GMT+01:00

Box	Nom	Passages	Alarmes	Caisse fermée	Etat
359855079248821	4	22	13	5	🔴
359855079248821	Portique 16				🔴
359855079248821	Portique 2				🔴
359855079248821	1	52	0	2	🟢
359855079248821	16				🔴
359855079248821	Portique Caisse n°5				🔴
359855079248821	17				🔴
359855079248821	2				🔴



EAS SOLUTIONS

RADIO FREQUENCY ANTENNAS

MONO | RF

THE MONO RF SERIES

The radio-frequency detection antennas were specifically designed to adapt to the most challenging environments.

Thanks to the **SmartPulse** technology, the antenna analyses and detects any disturbing element all the while it optimizes detection.

This technology reaches a **detection distance of 2,20m between two antennas** (with the Forstag Round - see p.44).

Once installed, the antenna self-adapts to its environment, hence limiting maintenance costs.

It can easily and perfectly be integrated in supermarkets, hypermarkets, hardware shops, stores or malls...

This series' antennas **work in the 8,2 MHz radiofrequency**, the international frequency for hard adhesive labels. They are compatible with labels from all brands.

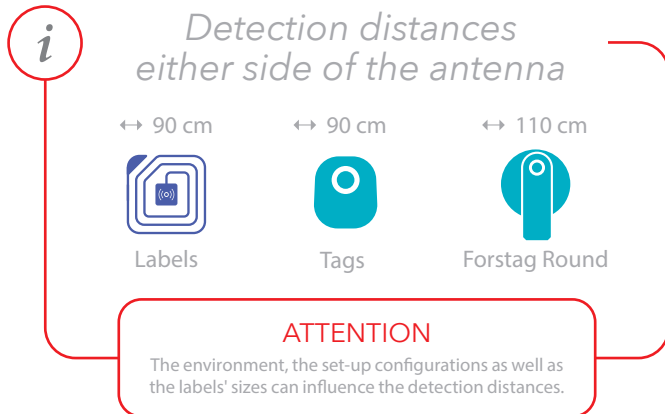

Backlighting
Permanent blue light effect and red alarm.



Hood Protection
Metal hood protection in 20/10th metal



Cart Protection
Metal tube and PMMA runner



Alarm
Red backlighting
Adjustable audio alarm

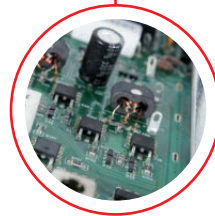

Smartpulse Technology
Last generation DSP with **SmartPulse** technology for a better detection

	FORS References	Product Name	Dimensions (mm) W x H x D
A	ARM-G3	Armony Plus Antenna	314 x 1 500 x 120
B	ARM-PC-G3	Armony Plus Antenna with cart protection	430 x 1 500 x 120
C	ARM-ALU-G3	Aluminium Armony Plus Antenna	360 x 1 495 x 40
D	ORC-G1	Orchestra Plus Antenna	314 x 1 500 x 65
E	ORC-PC-G1	Orchestra Plus Antenna with cart protection	430 x 1 500 x 65



EAS SOLUTIONS

RADIO FREQUENCY ANTENNAS

MONO | RF

ARMONY PLUS RF

Launched in 2015, the Armony antenna has seduced many clients (hypermarkets and retail) thanks to its design and ease in installation and set-up.

Over 300 hypermarkets and supermarkets currently have the ARM-G3 model in France and worldwide.



i

Strengths

- DSP with SmartPulse function
- Automatic interferences analysis
- Excellent detection
- Polyvalent antenna
- Design
- Performance stability in time
- Backlighting in blue (optional)



A

ARM-G3
Armony antenna
Plexiglass PMMA



B

ARM-PC-G3
Armony plexi with
cart protection



C

ARM-ALU-G3
Armony antenna
Aluminium coating

ORCHESTRA PLUS RF

The new Orchestra RF meets the new requirements for teletransmission (hypermarkets and retail) with its new design and exceptional ease in installation, set-up and online maintenance.



i

Strengths

- Same as Armony Plus RF
- Slim (65mm)
- Online maintenance (optional)
- People count (optional)
- Automatic analysis (optional)
- Beeper (optional)
- Backlighting in blue (optional)
- Passage & closed checkout alarm (optional)



FORScloud
Connected anten-
nas options page 11

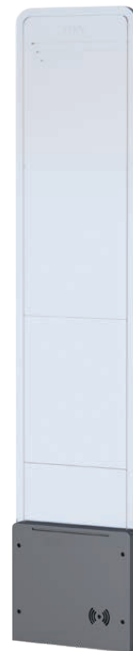

D

ORC-G1
Orchestra antenna
Plexiglass PMMA



E

ORC-PC-G1
Orchestra plexi
with cart protection



EAS SOLUTIONS

RADIO FREQUENCY ANTENNAS

DUO | RF

THE DUO RF SERIES

The **Symphony plus** radio-frequency antenna is perfectly adapted to retail stores, allowing for optimum detection between security gates.

Thanks to the **RxTx technology**, the antennas work in pairs (emitting/receiving).

The Symphony Plus series is composed of two models: Symphony Plexi and Symphony Alu. The technology and operation of both these antennas are the same, their only difference being in the design.

This technology allows to reach a **detection distance of 2,20m** between antennas (with the Forstag Round, see p.44).

This series' antennas **work in the 8,2 MHz radiofrequency**, the international frequency for hard adhesive labels. They are compatible with labels from all brands.

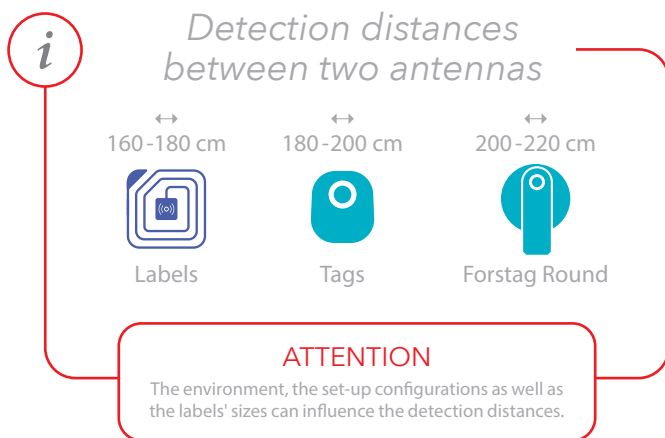

Ultra Slim

Only 4 mm thick at the base of the antenna



Design

Transparent PMMA antenna for total discretion



POS advertising

Possibility to include POS advertising or a plexiglass support



Alarm

Red backlighting
Adjustable audio alarm

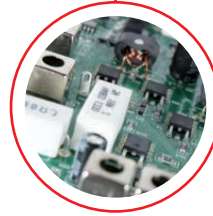

Embedded electronics

Last generation DSP with Rx-Tx technology for a better detection

	FORS References	Product Name	Dimensions (mm) W x H x D
A	SYM-PLE-RX	Symphony Plexi Rx Antenna	430 x 1 500 x 120
	SYM-PLE-TX	Symphony Plexi Tx Antenna	430 x 1 500 x 120
B	SYM-ALU-RX	Symphony Aluminium Rx Antenna	360 x 1 495 x 40
	SYM-ALU-TX	Symphony Aluminium Tx Antenna	360 x 1 495 x 40



EAS SOLUTIONS

RADIO FREQUENCY ANTENNAS

DUO | RF

SYMPHONY PLUS

Launched in 2015, the Symphony antenna has seduced many clients (hypermarkets and retail) thanks to its design and ease in installation and set-up. Its reliability in time has been proven.



i

Strengths

- DSP signal filtration
- Excellent detection
- POS advertising integration



A

SYM-PLE-RX | SYM-PLE-TX
Symphony antenna
PMMA Plexiglass

Symphony Plexi

- Slick design
- Slim



B

SYM-ALU-RX | SYM-ALU-TX
Symphony antenna
Aluminium coated

Symphony Alu

- Cost optimization
- Ultra Slim
- Better mechanical resistance (shocks and vandalism)





EAS SOLUTIONS

MAGNETO-ACOUSTIC ANTENNAS

DUO | AM

AM DUO SERIES

Perfect for prêt-à-porter stores, pharmacies, etc., our AM antennas include excellent detection and perfect interferences resistance.

This technology allows to reach a detection distance of 2,20m between two antennas (with the Rambo Tag, see p. 47), which frees your access point for customers passage.

The antennas of this series **work in magneto-acoustic at 58 KHz**, the international frequency for hard adhesive labels.

They are compatible with labels from all brands



Ultra Slim

Only 5 cm thick at the base of the antenna



Design

Transparent PMMA antenna for total discretion



POS advertising

Possibility to include POS advertising or a plexiglass support



Alarm

Red signal
Audio alarm

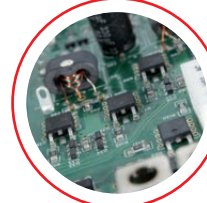

Embedded electronics

Last generation DSP with AM technology for a better detection



Detection distances between two antennas

	↔	↔	↔
30 cm antennas	130 cm	160 cm	200 cm
44 cm antennas	160 cm	180 cm	240 cm
52 cm antennas	180 cm	190 cm	250 cm



AM Labels



AM Tags



AM Forstags Rambo Tag

ATTENTION

The environment, the set-up configurations as well as the labels' sizes can influence the detection distances.





EAS SOLUTIONS

MAGNETO-ACOUSTIC ANTENNAS

DUO | AM

TEMPO

Specifically developed for pharmacies and retail stores wishing to use small adhesive labels, the Tempo series is already installed in 150 stores.

The three sizes of our antennas aim at meeting your needs in detection width, and our range of accessories will secure all of your products.



Strengths

- Slick design
- Excellent detection
- POS advertising integration
- Less sensitive to disturbances
- Low frequency



Detection distance between two antennas

30 cm antennas:
200 cm max.

44 cm antennas:
240 cm max.

52 cm antennas:
250 cm max.



A
TEM-ALU-G1
 Small Tempo antenna
 Width 302 mm



B
TEM-ALU-G2
 Large Tempo antenna
 Width 440 mm



C
TEM-ALU-G3
 Maxi Tempo antenna
 Width 520 mm

	FORS References	Product Name	Dimensions (mm) W x H x D
A	TEM-ALU-G1	Tempo Alu small antenna	302 x 1 530 x 50
B	TEM-ALU-G2	Tempo Alu large antenna	440 x 1 530 x 50
C	TEM-ALU-G3	Tempo Alu maxi antenna	520 x 1 530 x 60



EAS SOLUTIONS

METAL DETECTORS

METAL DETECTION

This antennas series is an additional solution for EAS antennas that allows to **fight boosterbags**.

Boosterbags are used by all organized crime gangs for shoplifting. They use them to prevent labels and tags detection so as not to trigger the EAS alarm when they exit the store with stolen products.

Depending on the environment, we will recommend the **Metalguard** series that detects all boosterbags, whether they are bags, jackets, pockets or baby strollers; or the **Hyperguard** series that also filtrates carts.

These solutions can be embedded to existing antennas or be installed separately.



METALGUARD

This antennas series detects metal, and most importantly boosterbags, whether they are bags, jackets, pockets or baby strollers.

They include a filter allowing an installation starting 70cm away from a moving door. **This eliminates any false alarm caused by moving doors.**

HYPERGUARD

This series includes all the Metalguard features and also includes a cart filter.

It allows installation in environments with carts and allows passage **without false alarms** (hypermarkets and supermarkets).

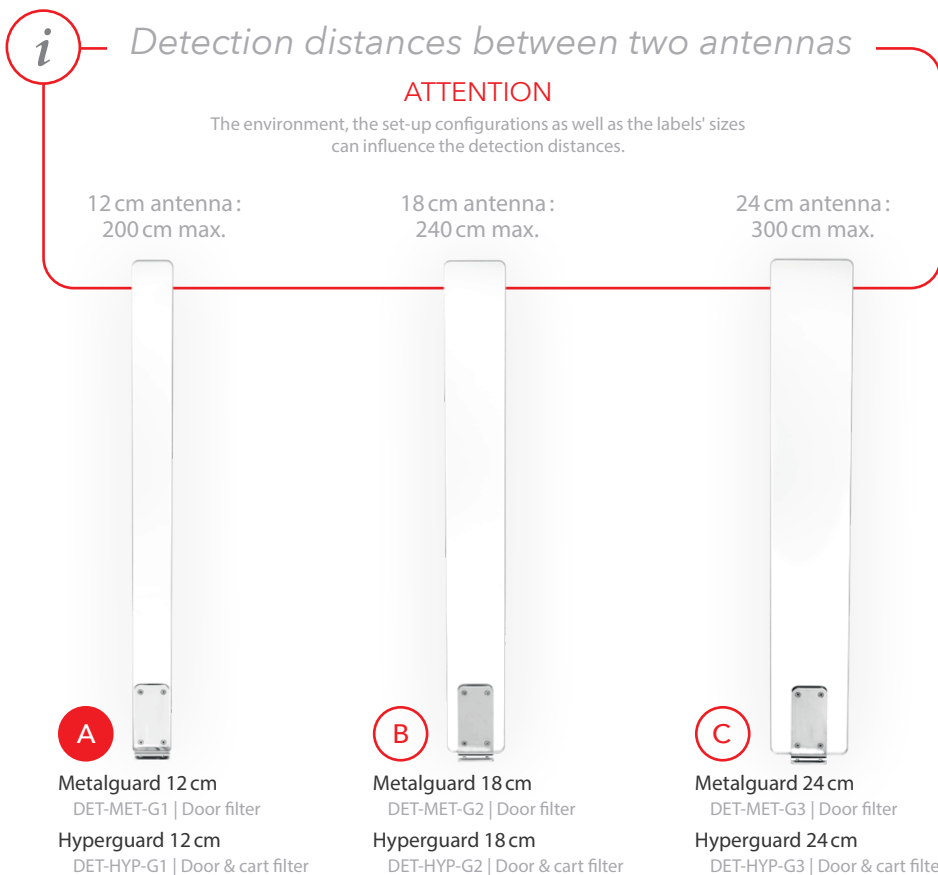



EAS SOLUTIONS

MAGNET DETECTORS

MAGNET DETECTION

Apparelguard antennas are installed in fitting rooms for magnetic detection, allowing to

identify illegal magnets before they are used for shoplifting.



Detection distance

Between 2 Apparelguard antennas:
140cm max.



Apparelguard
DET-APP
Magnet detection



ONE UNIQUE CONTROLLER

Metalguard, Hyperguard and Apparelguard solutions can be combined in order to allow for metal and magnet detection within a store. One case only, paired with an adaptable software, can control each of the series for up to 11 antennas.



Controller
DET-CON | 1 for 11 antennas

	FORS Reference	Product Name	Metal Detection	Door Filter	Cart Filter	Magnet Detection	RF & AM Compatible
A	DET-MET-G1	Metalguard 12cm	✓	✓	-	-	✓
	DET-HYP-G1	Hyperguard 12cm	✓	✓	✓	-	✓
B	DET-MET-G2	Metalguard 18cm	✓	✓	-	-	✓
	DET-HYP-G2	Hyperguard 18cm	✓	✓	✓	-	✓
C	DET-MET-G3	Metalguard 24cm	✓	✓	-	-	✓
	DET-HYP-G3	Hyperguard 24cm	✓	✓	✓	-	✓
D	DET-APP	Apparelguard	-	-	-	✓	✓
E	DET-CON	Controller	-	-	-	-	✓



DEACTIVATOR

FIXED DEACTIVATOR

Fixed deactivators can be installed under the cashier's checkout counter and be connected either to the scanner or a deactivation table or a pad (to place on or under the counter); they deactivate labels at checkout.

This set-up allows the cashier to maintain their work rhythm without disturbance, the label being automatically deactivated when the product is scanned or presented in front of the pad or the deactivation table. In the case of tags, they ring if they're not deactivated.



How the deactivation works

STORES WITH SCANNERS (RF)

The buckle is placed around the scanner and allows a deactivation space of 15 cm.

Deactivation buckle

The scanner must be pre-equipped with the deactivation buckle and its cable must be accessible under the checkout counter.

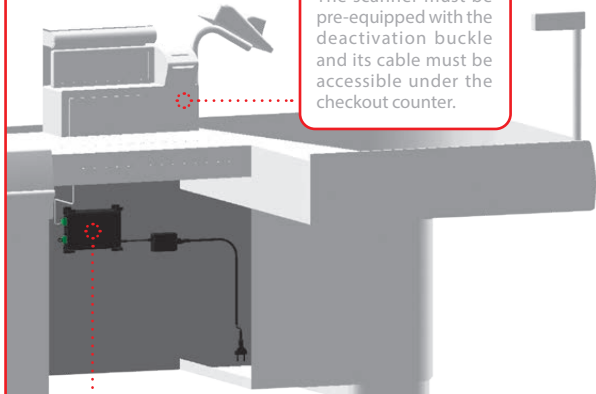

STORES WITH BARCODE READERS (RF & AM)

The buckle is placed in the pad or the deactivation table.

This set-up is adapted to stores equipped with barcode readers only. Deactivation space of 15 cm.

RF Pad - AM Pad - RF deactivation table

They can be placed in either of the 3 different types of store implementation.

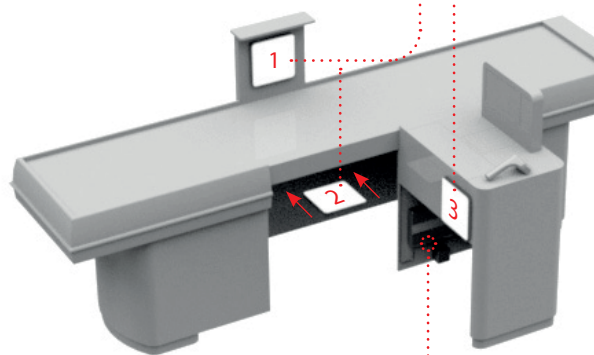

Deactivation case fixed under the checkout counter.

Lors de la désactivation de l'étiquette ou du tag (RF ou AM), l'hôtesse de caisse est alertée par un «bip» (volume réglable).

	FORS References	Product Name	Packing List	Package Weight
A	DESACRF2	Fixed RF deactivator	1	0,38 Kg
B	PAD	Pad RF deactivator	1	0,64 Kg
C	DESAPAD-RF	Table RF deactivator	1	0,90 Kg
D	DESACAM	Fixed AM deactivator	1	0,50 Kg
E	PADAM	Pad AM deactivator	1	0,70 Kg
F	DESACMAN	Manual RF detector and deactivator	1	0,20 Kg

● Best sellers



EAS SOLUTIONS

DEACTIVATION EQUIPMENT

RF DEACTIVATORS



A DESACRF2
RF deactivator
2 exits deactivator



B PAD
Pad RF deactivator
To place under the counter



C DESAPAD-RF
RF deactivator table

AM DEACTIVATORS



D DESACAM
AM deactivators



E PADAM
Pad AM deactivator
To place under the counter

Deactivator table

The deactivator table is installed at the checkout and must be connected to power.

This 2 in 1 solution allows to deactivate labels by pairing the pad and the deactivator.

DETECTOR & MANUAL RF DEACTIVATOR

With the importance of the source tagging protection, manual deactivators allow the security manager to deactivate labels as they enter the store.



F DESACMAN
Portable and manual RF
detector and deactivator

i

Detector mode

In **position I**, press once on the red button to deactivate anti-theft labels and 8,2 MHz hard tags. In case of detection, it will produce a **continuous beep**.

Deactivator mode

In **position II**, press once on the red button to deactivate the labels within a 15 cm distance, when the label is deactivated, the device produces a **short beep**.



- O** Turned off
- I** Detector mode
- II** Deactivator mode

Detection and deactivation button

Charging



EAS SOLUTIONS

OPTIONS



PROTECTION EDGE

Protection edge preventing the detection on one side of the antenna and isolating from disturbances.

To use only with RF antennas.

A ARM-JOUE
Protection edge

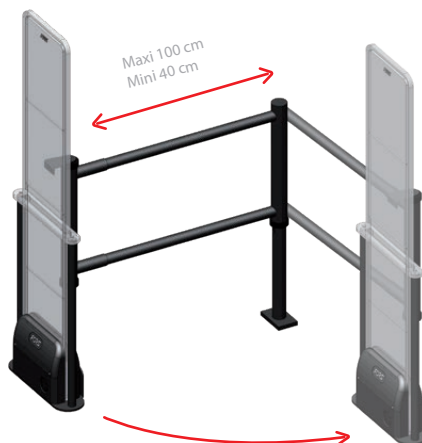

ROTATION SYSTEM

The rotation system allows to easily move the antenna on a rotation axis so as to obtain two passage units for emergency exits (depending on legal requirements).

This technologie also makes pallets passage easier.

B ARM-PIVOT
Rotation system

METAL SCANNER : PEOPLE SAFETY

The manual metal detector was conceived to meet the very precise needs of the professionals in people safety.

It was developed to facilitate the research of offensive weapons in the following areas :

- Border security,
- Postal sorting for packages check
- Malls, city halls, schools and public places, show venues, etc.

Specifications

Power: 9V (6F22) Standard or chargeable battery

Frequency: 25KHz

Tension: 9V (6F22)

Weight: 400g (without battery)

Size: 41 (L) x 8 (l) x 4,2 cm (H)

Temperature range for use: -15°C à 55°C

It has a low battery indicator.

The sensitivity of the detector is determined by the size, shape and composition of the object to detect.

Typical performance data states below :

OBJECT	SENSITIVITY
Pin	30 - 60 mm
Coins	75 - 100 mm
15 cm knife	160 - 180 mm
Gun	180 - 195 mm

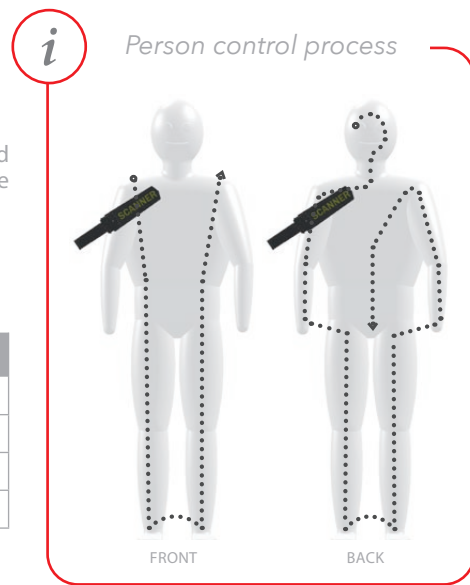

C DETMETAL
Metal scanner
(people safety)

	FORS References	Product Name	Dimensions (mm) W x H x D
A	ARM-JOUE	Protection element	665 x 1587 x 176
B	ARM-PIVOT	Rotation element	From 40 to 1000 mm
C	DETMETAL	Metal scanner	Packing list : 1 for 0,2 kg
D	KIT-CAM4	Video protection pack	4 cameras



EAS SOLUTIONS

VIDEO PROTECTION

VIDEO PROTECTION

Our video surveillance system is the indispensable tool to protect your products and staff in-store.

The video coverage of the most sensitive areas strengthens the global security of your store.

Real time surveillance paired with the recording of images allows for great reactivity on shoplifting attempts; it also gives the ability to look back after a theft was discovered. You can also access the images through the mobile application for more convenience.

- IP cameras with night vision
- High resolution up to 1080p
- Long distance WiFi or Ethernet
- Simple to set-up and use
- 360 degrees rotation axis
- Real time visualization
- Remote connection
- Video recording and storage
- Movement detection
- Alert notification



D Video protection pack
KIT-CAM4 | One access box
4 high performance cameras



We offer an all in one pack including 4 high performance cameras and the box to connect them.

Our video system is customizable and allows you to add additional cameras according to your needs.

i

Robustness

- Metal shell
- Waterproof IP66
- Admissible temperatures: -21°C à +56°C
- Can be used outside: the cameras are rain and snow proof.

Simplicity

- Plug and play: the cameras are automatically detected and connected.
- Its 360° rotation axis makes the installation of cameras at the desired locations easy: counter, wall, ceiling...
- Remote access on computer or mobile through the application.
- Confidentiality mask: you can select sensitive areas and areas to ignore so as not to be notified with a false-alarm.
- Smart reading: with customizable research zones, you will save on verification time.

Security

- The 36 infrared LED's and its smart filter guarantee high level pictures day and night.
- Movement detection.
- Automatic storage of the video in case of detection.
- Alert notification on your smartphone or by e-mail including informations in real time to act rapidly.



PEOPLE COUNT



The people count devices offer a measurement of the people flow at the accesses they are set up in.

PEOPLE COUNT ANTENNA

The embedded count device is a simple and efficient option that you can choose on our Orchestra antennas (p. 13).



SMART COUNT DEVICE

- LCD display
- Batteries
- 8 m distance operation



Software included

Functionality of the software provided with the equipment

- Automatic download of the count devices statistics (only if the software runs at all times in the background)
- Possibility to manage several devices per shop
- Windows compatible



Easy to use



Wireless USB to recover data on the computer - must be less than 8m from the people count devices

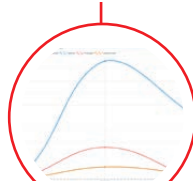

Statistics



Count Statistics

Statistics in tables or graphics :

- Per hour
- Per week
- Per day
- Per month



A SMART-N
SMART people count device
Batteries
Easy set-up

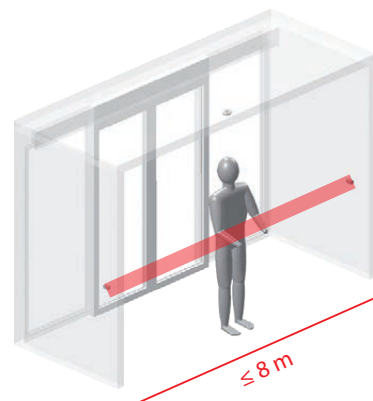



EAS SOLUTIONS

PEOPLE COUNT

2D CAMERA COUNTER

Economical and precise, the 2D camera counter is the ideal counting solution in stores, visitor centers and indoor public places. It has great advantages :

- Entry and exit counting
- 95% reliability (insensitive to light variations)
- Counting validation by video recording
- Can work by impulsion
- Easy to install (only needs one network cable between entrance and the venue router)
- One month memory
- Must be plugged in
- Can be set-up on ceiling



Software included



B CAMERA-2D
2D camera counter
Must be plugged in
Can be set-up on ceiling

i Detection according to height

Height	Detection width
2,5 m	2,6 m
3,0 m	3,1 m
3,5 m	3,7 m
4,0 m	4,1 m
4,5 m	3,5 m

i Functionalities of the software provided with the equipment

RPOS :
The "real time" software was designed for in-store visualization.

CPOS :
The statistics software allows you to establish daily, weekly, monthly and yearly reports.

REPORTING AND ANALYSIS

Reporting and analysis offer a better follow-up of your store from anywhere. See p.11 for more information on ForsCloud solutions.

	FORS References	Product Name	Packing List	Package Weight
A	SMART-N	SMART people count device	1	0,2 kg
B	CAMERA-2D	2D camera counter	1	0,2 kg



GATES GUIDANCE

GUIDANCE AND FLUX CONTROL



EMERGENCY EXIT

Security gates with notches allowing passage in case of emergency



EXIT WITHOUT PURCHASE

The manual security gates for exit without purchase can be controlled with a simple button by your cashier.

The installation of mechanical gates is also a possibility, in the direction you need.



AUTOMATIC GATES

The automatic gates are an economical solution to secure the entrance of your store.

It automatically opens when a client comes close. This new model **Easy Gate NG** includes the latest ITAB innovations.

If someone takes the gates reversely, the alarm sets off.



GUIDANCE BAR

Securing a store entrance or exit is made easier with the chromed guidance bars.

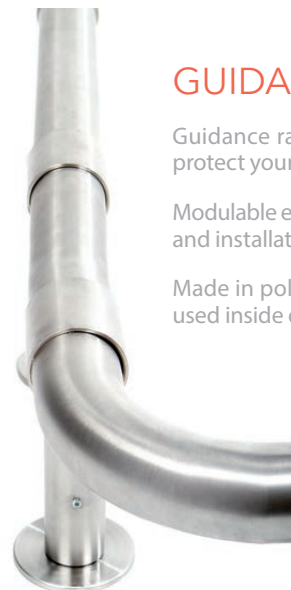

GUIDANCE RAILS

Guidance rails fixed on the ground allow to protect your furniture against cart shocks.

Modulable elements allow for an easy planning and installation.

Made in polished stainless steel, they can be used inside or outside.



GATES GUIDANCE

GUIDANCE AND FLUX CONTROL



SELF-SERVICE SOLUTION

The self-service solution allows the opening of the security gates upon presentation of a barcode printed on the receipt.

This system reduces shoplifting and guarantees a high security level at automatic checkout.



THE EASY GATE NG SOLUTION

It is our latest series, with a practical, robust and modern design.

The new **EasyGate NG** combines the best of the Flexigate and EasyGate standard series all the while benefitting from the latest technology and components on the market.

Its compact format allows for an easy installation, no matter what your store's configuration is.

The **EasyGate NG** was designed to create a perfect harmony between the series products - arms, guidance bars, etc.

The anti-panic function and audio alarm are included, and the alarm sets off if the gates arm is pushed in the anti-panic mode.

THE EASYGATE NG SERIES CAN BE INSTALLED IN THE FOLLOWING CONFIGURATIONS :

- Standard mode (standard automatic opening)
- Welcome mode (open gates that close back if someone goes through reversely)
- Secured mode (double gates)
- Cleaning mode (all doors can be open at once thanks to an optional command panel)

SPECIFICITIES

- Anti-panic function allowing for reversed unlocking of the gates
- 90 degrees arm opening
- Liaison and sync of several gates (by GateCom)
- Adjustable anti-panic power

TECHNICAL DATA

- Opening time: 1,5 s
- Closing time: 2,5 s
- Anti-panic power: 40 to 75 Nm
- Signal type: NPN, 12 VDC
- Settings: anti-panic power, opening and closing times
- Motor powering: 12 VDC
- Power: 230V

RFID SOLUTIONS

OUR GOAL: MAKE THE CUSTOMER'S
BUYING EXPERIENCE BETTER AND
INCREASE SALES IN RETAIL SHOPS
THANKS TO THE RFID TECHNOLOGY.

*Associated to other technologies,
the RFID technology is a major
factor in changes to come and is
becoming key for the overall cus-
tomer experience.*

*Thanks to the RFID technology,
the buying process is optimized
and allows the store to increase
profitability.*

*The offer becomes interactive, cus-
tomized and contextualized.*



- Why choose the RFID technology? 30
- Application systems :
 - RFID encoding systems 33
 - Automatic inventory systems 33
 - Interactive sales systems 34
 - Fast checkout systems 34
 - Anti-theft systems 35
 - Cloud based software platform 35
- Global offer 36

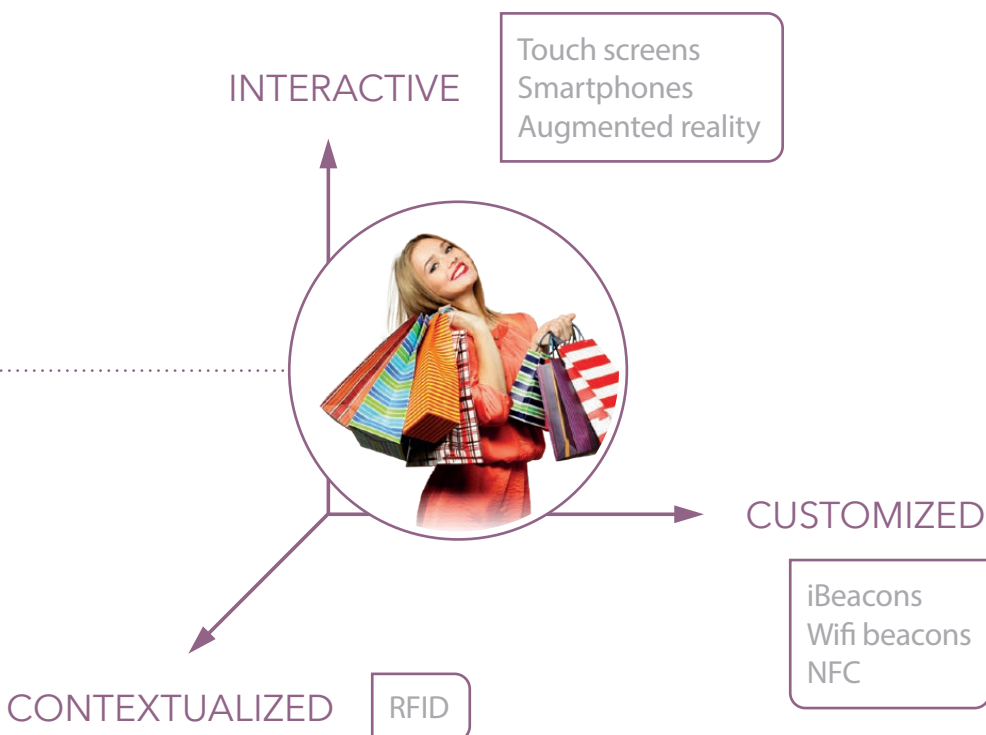

WHAT IS THE RFID TECHNOLOGY? WHY IS IT TRULY AN ASSET?



The obstacles met by customers throughout the buying process reduce in-store sales. There are many:

- Gates at the entrance
- Difficulty to find a product
- Sold out products
- Difficulty to see a product
- Difficulty to ask for another size from the fitting room
- Long lines at checkout



The RFID solution reduces these obstacles and makes the buying experience better while increasing sales.





RFID SOLUTIONS

WHY CHOOSE THE RFID TECHNOLOGY?

THE RFID TECHNOLOGY ALLOWS CONTEXTUALIZATION

Retailers intensely use websites' recommendations and this causes a great increase in revenue:

Online recommendations are decisive for the purchase decision.

Customers will be more likely to buy if they receive recommendations.

- 770% of the Amazon homepage is dedicated to product recommendations
- 35% of Amazon's sales come from recommendations
- The vast majority of movies watched on Netflix come from recommendations
- On online shops, recommendations increase revenue by 5 to 15%

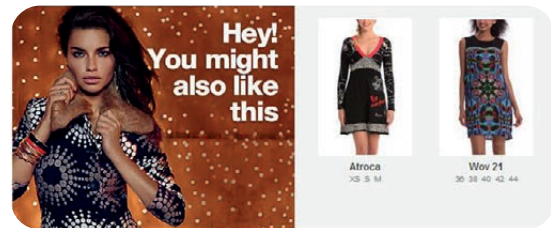

However, the infrastructure in-store is usually not interactive. It doesn't provide customers with recommendations.

RFID allows to contextualize and bring this new dimension into stores.

THE ADVANTAGES OF THE RFID TECHNOLOGY

For the customer

- Reduces annoying buying experiences
- Provides customized recommendations, avoids lack of information
- Follow-up of the delivery in real time
- Avoids long lines
- Avoids sold-out products

For you

- Flexibility in the store's management (inventory, stock...)
- Use the recommendations to increase your revenue
- Retain customers
- More information on the product
- Easier and more frequent restock
- Wide reach of anti-theft devices
- Identification of stolen products





RFID SOLUTIONS

APPLICATION SYSTEMS

THE RFID SOLUTIONS

We built a complete series of systems around this technology, allowing to make the customer experience better.



Cloud based software platform



RFID encoding systems

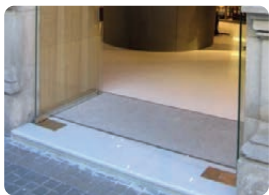

Anti-theft systems

Automatic inventory systems



Fast checkout systems



Interactive sales systems



RFID ENCODING SYSTEMS

Solutions to simply and quickly encode RFID tags: in factory, storages and stores.

ForsPrint

(Android or Windows)

Cloud system for encoding and printing for RFID labels.



ForsStation

Encoding stations for labels and RFID tags.



ForsScan

Mobile reader for encoding.



ForsScan allows to do an RFID inventory thanks to its Android mobile reader, as well as direct download of data in the cloud.

AUTOMATIC INVENTORY SYSTEMS

Inventory systems increase goods availability and reduce losses.

ForsTrack

Overhead systems for real-time inventory.



ForsRobot

Automatic robotic inventory.



ForsShelf

Smart shelves.





RFID SOLUTIONS

APPLICATION SYSTEMS

INTERACTIVE SALES SYSTEMS

Interactive crossed sales systems make the buying experience better for the customer and increase sales.

ForsServe

Mobile recommendations systems based on smartphones.

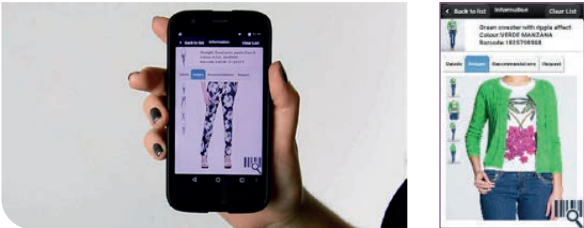

ForsFitting

Interactive fitting rooms systems.

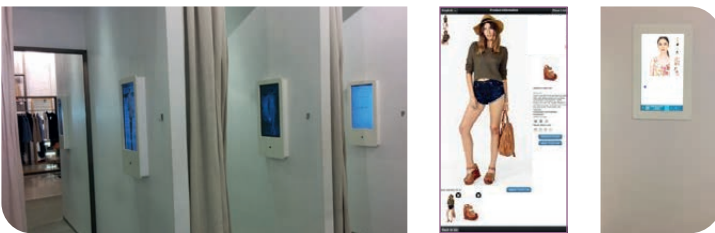

ForsLook

Crossed sales recommendations systems.



ForsMirror

Smart mirror with RFID and augmented reality.



FAST CHECKOUT SYSTEMS

Fast checkout systems make the payment process faster and reduce lines.

ForsPay 110

RFID checkout: reading and writing on RFID labels.

ForsPay 160

Reading/writing checkout points and tag removers.





RFID SOLUTIONS

APPLICATION SYSTEMS

ANTI-THEFT SYSTEMS

These new anti-theft systems make access to stores completely free, which attracts more consumers.



ForsMat

Mat with embedded antennas.

ForsGuard

RFID alarm unit.



ForsGate

RFID gates.

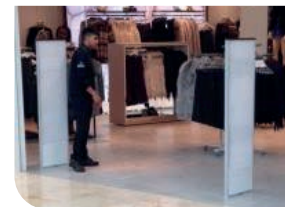

ForsSafe

Overhead anti-theft system.



CLOUD BASED SOFTWARE PLATFORM

Our RFID systems are managed and controlled remotely through a cloud software platform, that keeps the RFID data as well as customers interactions.

ForsCloud

Web software platform for:

- Controlling systems remotely
- Downloading contents for stores
- Keeping RFID data and customers interactions

Our ForsCloud platform is accessible through a trimestrial subscription.

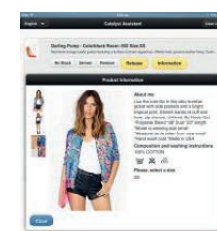
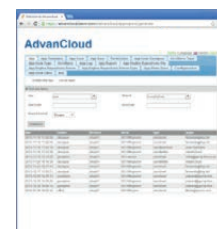



GLOBAL RFID OFFER

The RFID offer has different levels: Components, systems, software drivers, cloud platform and diverse services.

Software tools

- ForsNet API

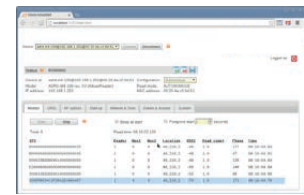

Software applications

- Monitoring
- Control panels, reports
- Inventory management

Cloud based software platform



- Encoding
- Inventory data

Systems



Material components



Readers



Splitters



Connection cards



Dephasers



RFID SOLUTIONS

GLOBAL OFFER

- ForsNet Manager (web tool configuration)



- Content management

Basic services

- Installation
- Online and on-site maintenance
- Customization of user interface
- Data and content hosting

Optional services

- Content updates
- Software development
- Software integration
- Business intelligence
- Material financing

- Customer interaction
- Content hosting and distribution



- Event archives
- Material control, alerts, firmware updates



Interactive systems



Checkout systems



Anti-theft systems



Multiplexers

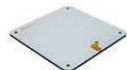

Antennas



RF cables and adaptors



Accessories

EAS ACCESSORIES

FORSTAG INNOVATIVE SOLUTIONS

The new ForsTag box introduces the ForsTag concept and its large series.



The ForsTag box presents some of our best-sellers for the Alcohol, Cosmetics, Multimedia and Retail departments to prevent shoplifting.

You can complete it with any equipment assortment presented in this catalogue.

FORSTAG
INNOVATIVE SOLUTIONS

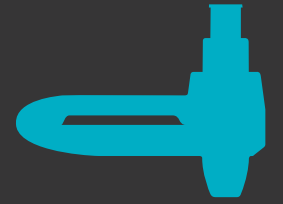

- Labels 40
- Forstag Innovative Solutions 42
- Retail accessories :
 - Forstag solution 44
 - RF tags 46
 - AM tags 47
 - Pins and adjustable anti-theft devices 48
 - Glasses accessory 49
- Food and beverage :
 - Bottles 50
 - Cans and food 54
- Spiders and alarm-equipped anti-theft devices : 56
- Spindle protections : 58
- Tag removers and security levels : 59





EAS ACCESSORIES

LABELS

RF LABELS

To make the detection distance larger, choose the bigger size labels which benefit from a larger electronic circuit.

The Fors radio frequency anti-theft labels benefit from an excellent detection rate.



A Label 3x3 White
RF3-DB | Deactivable



B Label 4x3 White
RF43-DB | Deactivable



C Label 4x4 White
RF4-DB | Deactivable
RF4-NDCB | Non Deactivable



D Label 5x5 White
RF5-DB | Deactivable
RF5-NDCB | Non Deactivable



E Label 3x3 Bar code
RF3-DCB | Deactivable



F Label 4x3 Bar code
RF43-DCB | Deactivable



G Label 4x4 Bar code
RF4-DCB | Deactivable
RF4-NDCB | Non Deactivable



H Label 5x5 Bar code
RF5-DCB | Deactivable
RF5-NDCB | Non Deactivable



I Label 3x3 Black
RF3-DN | Deactivable



J Label 4x4 Black
RF4-NDN | Non Deactivable



K Label Red Heart
RF4-COEUR | Deactivable



L Label Plastic Insert
RF4-INS | Deactivable

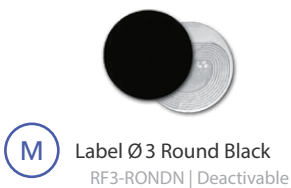

M Label Ø3 Round Black
RF3-RONDN | Deactivable



N Label Ø4 Round Black
RF4-RONDN | Deactivable



O Label Ø4 Round White
RF4-RONDB | Deactivable

SPECIFIC RF LABELS

Easily customize your labels thanks to the labels printable on thermal printers.

The food labels meet the food products requirements.



P Label 4x4 Thermal
RF4-DBTH | Deactivable



Q Label Frais 4x4 Bar code
RF4-DCBF | Deactivable



R Label 4x4 "Alcohol abuse..."
RF4-LOGO-SANTE | Deactivable
Étiquette discrète avec texte

AM LABELS



S AM Label White
AM-DB | Deactivable
AM-NDB | Non Deactivable



T AM Label Bar code
AM-DCB | Deactivable



U AM Label Plastic Insert
AM-DCB-INS | Deactivable



EAS ACCESSORIES

LABELS

TRANSPARENT RF LABELS

Transparent labels are more discreet and will blend more easily on cosmetics and small products.



V Label 6,5x1,9 Transparent
RF6-DTR | Deactivable



W Label 5x2,3 Transparent
RF5-DTR | Deactivable

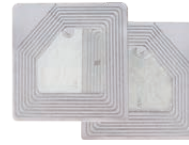

X Label 4x4 Transparent
RF4-DTR | Deactivable

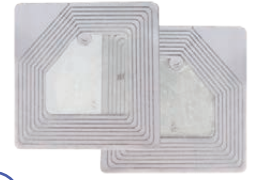

Y Label 5x5 Transparent
RF55-DTR | Deactivable

	FORS reference	Product Name	Size (mm) WxH	Technology	Color	Packing list	Package weight
A	RF3-DB	Label 3x3 White Deactivable	30x30	RF	○	1 000	0,50 kg
B	RF43-DB	Label 4x3 White Deactivable	40x30	RF	○	1 000	0,50 kg
C	RF4-DB	Label 4x4 White Deactivable	40x40	RF	●	1 000	0,50 kg
	RF4-NDB	Label 4x4 White Non Deactivable	40x40	RF	●	1 000	0,50 kg
D	RF5-DB	Label 5x5 White Deactivable	50x50	RF	●	1 000	0,50 kg
	RF5-NDB	Label 5x5 White Non Deactivable	50x50	RF	●	1 000	0,50 kg
E	RF3-DCB	Label 3x3 Bar Codes Deactivable	30x30	RF	▮▮▮▮	1 000	0,50 kg
F	RF43-DCB	Label 4x3 Bar Codes Deactivable	40x30	RF	▮▮▮▮	1 000	0,50 kg
G	RF4-DCB	Label 4x4 Bar Codes Deactivable	40x40	RF	▮▮▮▮	1 000	0,50 kg
	RF4-NDCB	Label 4x4 Bar Codes Non Deactivable	40x40	RF	▮▮▮▮	1 000	0,50 kg
H	RF5-DCB	Label 5x5 Bar Codes Deactivable	50x50	RF	▮▮▮▮	1 000	0,50 kg
	RF5-NDCB	Label 5x5 Bar Codes Non Deactivable	50x50	RF	▮▮▮▮	1 000	0,50 kg
I	RF3-DN	Label 3x3 Black Deactivable	30x30	RF	●	1 000	0,90 kg
J	RF4-NDN	Label 4x4 Black Non Deactivable	40x40	RF	●	1 000	0,90 kg
K	RF4-COEUR	Label Heart	40x40	RF	●	1 000	0,55 kg
L	RF4-INS	Label Plastic Insert RF	40x40	RF	○	1 000	0,90 kg
M	RF3-RONDN	Label Ø3 Round Black	Ø 30	RF	●	1 000	0,45 kg
N	RF4-RONDN	Label Ø4 Round Black	Ø 40	RF	●	1 000	0,45 kg
O	RF4-RONDB	Label Ø4 Round White	Ø 40	RF	○	1 000	0,38 kg
P	RF4-DBTH	Label 4x4 THERMAL Deactivable	40x40	RF	●	1 000	0,50 kg
Q	RF4-DCBF	Label 4x4 FOOD Bar Code Deactivable	40x40	RF	▮▮▮▮	1 000	0,50 kg
R	RF4-LOGO-SANTE	Label 4x4 HEALTH ALCOHOL Deactivable	40x40	RF	○	1 000	0,50 kg
S	AM-DB	AM Label White Deactivable	44x11	AM	●	1 000	1,00 kg
	AM-NDB	AM Label White Non Deactivable	44x11	AM	○	1 000	1,00 kg
T	AM-DCB	AM Label Bar Code Non Deactivable	44x11	AM	▮▮▮▮	1 000	1,00 kg
U	AM-DCB-INS	AM Label Plastic Insert Deactivable	44x11	AM	○	1 000	1,00 kg
V	RF6-DTR	Label 6x1,9 Transparent Deactivable	60x19	RF	Colorless	1 000	0,45 kg
W	RF5-DTR	Label 5x2,3 Transparent Deactivable	50x23	RF	Colorless	1 000	0,45 kg
X	RF4-DTR	Label 4x4 Transparent Deactivable	40x40	RF	Colorless	1 000	0,80 kg
Y	RF55-DTR	Label 5x5 Transparent Deactivable	50x50	RF	Colorless	1 000	0,80 kg

● Best-sellers

▮▮▮▮ Bar code

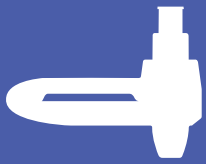

EAS ACCESSORIES

FORSTAG INNOVATIVE SOLUTIONS

FORSTAG INNOVATIVE SOLUTIONS

The all-in-one solution to protect your products



HOW TO USE THE FORSTAG

Simple and quick locking process

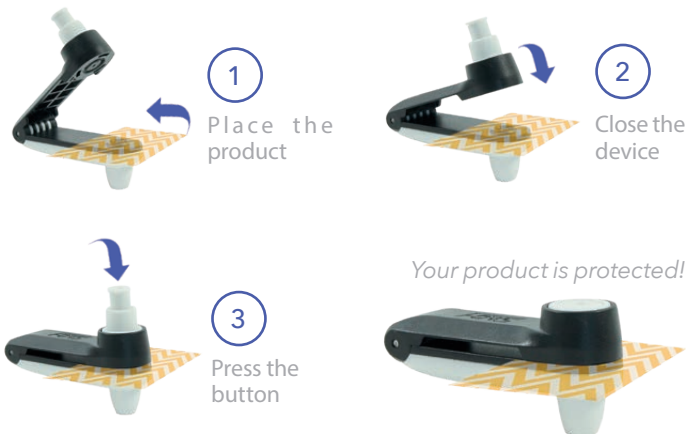

Instantaneous unlocking

When the unlocking device touches the tag, it's instantaneously unlocked.



Strengths of the Forstag

SMART DESIGN

- Discreet, beautiful and ready to use
- Possibility to customize the series for large orders
- All-in-one system (pin + pliers + detection):
 - Less separate items loss
 - Unique storage basket at checkout and in the back office
- Retractable pin to avoid injury
- Locking and unlocking simple and fast:
 - Forstag can be installed with one hand only
 - Time-saving
- Products delivered unlocked
- FORS exclusive patent



RESPECT OF THE PRODUCTS

- Smooth pin so as not to damage the clothes
- Possibility to protect specific products thanks to a notch. Great for belts, cables, braces, lingerie, etc.

SECURITY

- RF, AM or RFID Technology
- 3 levels of security available with standard, super-lock or hyper-lock magnetic system (more information p. 59)

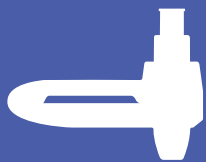

EAS ACCESSORIES

FORSTAG INNOVATIVE SOLUTIONS



FORSTAG Blister
p. 45



Boîtier Blister USB
p.53



FORSTAG Trad
p. 44



FORSTAG Alcool
p. 50

AN ECONOMICAL SOLUTION

More productivity

Because it is so easy to use, the FORSTAG series offers stores staff more security, which in returns causes better efficiency daily.

More comfort in fastidious and repetitive tasks leads to a better productivity.

Global cost: investment, workforce costs and economy rates over 5 years

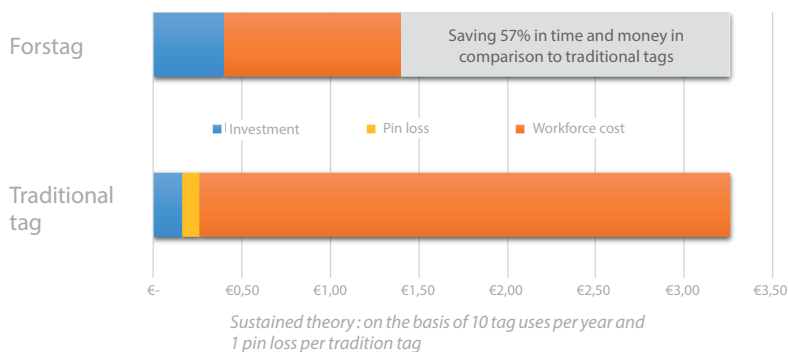

HYGIENE AND SECURITY: RETRACTABLE PIN

We all know it, manipulating anti-theft pins causes security and hygiene issues for staff.

In its open position, the Forstag pin is invisible: this innovation allows staff to manipulate the product without risking an injury.

To lock the Forstag, simply press the button.



FORSTAG INK
p. 44



FORSTAG Champagne
p. 51



FORSTAG Round
p. 44



FORSTAG Vin
p. 51



FORSTAG PADLOCK 3
p. 45



CAN-TAG 1, 2 et 4
p. 55



FORSTAG PADLOCK 2
p. 45



CAN-TAG 3
p. 55

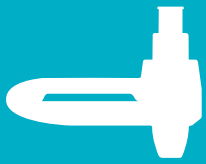

EAS ACCESSORIES

ANTI-THEFT TAGS

TAGS

We offer a large range of tags of different shapes and forms, to meet all your needs on the ground. Find all of our references in the Forstag series for textiles.

Small, light and compact, the Forstag will protect your products in a discreet, durable and elegant.



FORSTAG INNOVATIVE SOLUTIONS

Forstag: an economical solution

Putting on + Dropping off + Collecting:
(Average use time estimate)



Time	Tag + Pin	Forstag
Collect	2 sec	1 sec
Putting on	6 sec	1,5 sec
Dropping off	4 sec	1,5 sec
Total	12 sec	4 sec

Respect of the products

A smart slit allows to place the bra straps, handles, cables without damaging the garments.



A Forstag Trad
FTTRA
All-in-one textile tag



B Forstag Round
FTROU
Maximal detection



C Forstag Ink
FTINK
With ink



CUSTOMIZABLE TAGS

This series allows you to use your anti-theft devices to communicate.



D BLUE BOX
RF35-HL
Logo option



Customized Forstag

With your specification, the Forstag range can be easily customized.



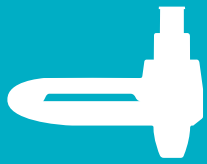

EAS ACCESSORIES

ANTI-THEFT TAGS

FORSTAG PADLOCKS

Thanks to its wide handle, the Forstag Padlock series is the perfect solution to protect leather goods, fashion accessories, sports accessories, strollers, shoes, etc.

The metal handle guarantees maximum security for your products, since the anti-theft device cannot be cut with simple tools or a pair of scissors.



E **FORS**
exclusive
Patent

Pad Lock 2

FTPL2 | Fashion or sport accessories, etc.



F **FORS**
exclusive
Patent

Pad Lock 3

FTPL3 | Leather goods, jewelry...

FORSTAG
INNOVATIVE SOLUTIONS



FORSTAG BLISTER

With its folding hook, the Forstag Blister was designed to adapt to products presented under a blister packaging.

Not bulky, it can easily adapt to existing shelves.































FORS
exclusive
Patent

G

Forstag Blister

FTBLI | Blister protection



	FORS Reference	Product Name	Size (mm) W x H x D	Technology	Color	Packing List	Package Weight
A	FTTRA	Forstag Trad	60x19x30	RF ou AM    	● ○	100	1,80 kg
B	FTROU	Forstag Round	49x65x30	RF    	● ○	100	1,80 kg
C	FTINK	Forstag Ink	60x19x30	RF ou AM    	● ○	100	1,80 kg
D	RF35-HL	Blue Box	Ø 35	RF    	● ○	100	1,70 kg
E	FTPL2	Pad Lock 2	60x60x35	RF / AM    	● ○	50	1,25 kg
F	FTPL3	Pad Lock 3	80x35x34	RF / AM    	● ○	50	1,40 kg
G	FTBLI	Forstag Blister	60x19x30	RF / AM    	● ○	100	1,90 kg

  Best-sellers



Available security levels: see p. 59

 Audio alarm

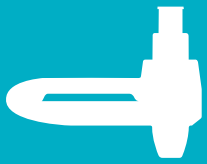

EAS ACCESSORIES

ANTI-THEFT TAGS

RF TAGS

Our tags range works in the international radio frequency range: 8,2 MHz. Our products are compatible with any existing store installed antenna using this technology.

Depending on the opening magnetic power set up and the desired detection level, these equipments exist in different variations and can bring, according to the set-up, the best fitted solution to your products' security.



A Rectangular tag
RF4248
With lanyard hole



B Round tag
RFROND55
With lanyard hole



C Triangular tag
RFT32B



D White lock
VERB
Ultra compact



E Mini pencil RF black
RFPENCIL
Compact tag

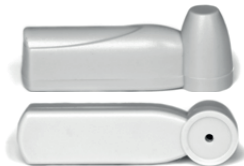

F Mini pencil RF gray
RFPENCIL-G
Compact tag



G Mini pencil lanyard
RFLAN-90
Lanyard 90 mm



H Maxi pencil lanyard
RFLAN-170
Lanyard 170 mm



I Tao black tag
RF50N-SL



J Tao white tag
RF50B



K R30 tag
RF30N-SL
With lanyard hole



L Golf tag 64 mm
RFGM-64N



M Golf tag 50 mm
RFGM-50N



N Smooth golf tag 50 mm
RFGL-50N



O Smooth golf tag 45 mm black
RFGL-45N



P Smooth golf tag 45 mm white
RFGL-45B

i

Tags with this pin pictogram include a pin with a shape adapted to the tag, in a complete system.

Tags with this pictogram are standalone tags and must be completed with a pin: See page 48 for pins informations (all pins are compatible).

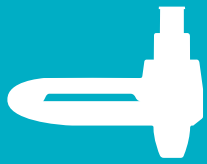

EAS ACCESSORIES

ANTI-THEFT TAGS

AM TAGS

Our tags range works in the international acousto magnetic frequency : 58 KHz. Our products are compatible with any existing store installed antenna using this technology.

Depending on the opening magnetic power set up and the desired detection level, these equipments exist in different models and can bring, according to your set-up, the best fitted solution to your products' security.



Q Mini pencil lanyard AM
AMLAN-90B
Lanyard 90 mm



R Mini pencil AM gray
AMPENCIL
Compact tag

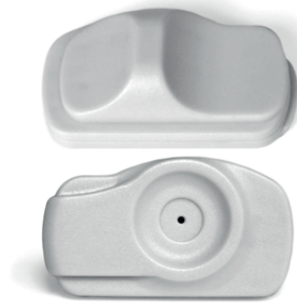

S Sensor tag
AMS55G
Acousto-magnetic



T Rambo Tag
AMRAMBO

	FORS Reference	Product Name	Size (mm) WxHxD	Technology	Color	Packing List	Package Weight
A	RF4248	RF rectangular tag	42x48x16	RF	●	100	1,00 kg
B	RFROND55	RF round tag	∅ 50x16	RF	○	100	1,20 kg
C	RFT32B	RF triangular tag	30x18x30	RF	○	100	1,00kg
D	VERB	White lock Tagt	∅ 18x17	RF	○	100	0,07kg
E	RFPENCIL	Mini pencil RF black	49x18x13	RF	●	100	1,00kg
F	RFPENCIL-G	Mini pencil RF grey	49x18x13	RF	●	100	1,00kg
G	RFLAN-90	Mini pencil lanyard RF	140 mm	RF	●	100	1,20kg
H	RFLAN-170	Maxi pencil lanyard RF	170 mm	RF	●	100	1,50kg
I	RF50N-SL	Tao black tag	∅ 50x19	RF	●	100	1,20kg
J	RF50B	Tao white tag	∅ 50x24	RF	○	100	1,70kg
K	RF30N-SL	R30 tag	∅ 30x22	RF	●	100	1,10kg
L	RFGM-64N	Golf 64 mm tag	∅ 64x22,4	RF	●	100	2,20kg
M	RFGM-50N	Golf 50 mm tag	∅ 50x22,2	RF	●	100	1,70kg
N	RFGL-50N	Golf smooth 50 mm tag	∅ 50x21,9	RF	●	100	1,70kg
O	RFGL-45N	Golf smooth 45 mm black tag	∅ 45x23,5	RF	●	100	1,50kg
P	RFGL-45B	Golf smooth 45 mm white tag	∅ 45x23,5	RF	○	100	1,50kg
Q	AMLAN-90B	Mini pencil lanyard AM	140 mm	AM	○	100	1,00kg
R	AMPENCIL	Mini pencil AM gray	49x18x13	AM	●	100	1,00kg
S	AMS55G	Sensor tag	53x18x23	AM	●	100	1,40kg
T	AMRAMBO	Rambo tag	68x26x21	AM	●	100	1,80 kg

Best-sellers

Available security levels : see p. 59

Audio alarm



EAS ACCESSORIES

ANTI-THEFT TAGS

PINS

Pins allow to lock tags on clothes.

SMOOTH PINS

Smooth models lock clothing without damaging the material.



A Smooth pin flat head
CLOU-16 | 16 mm
CLOU-19 | 19 mm



B Smooth pin rounded head
CLOU16-TB | 16 mm



C Smooth pin conical head
CLOU16-TC | 16 mm

NOTCHED PINS

Notched models allow for an optimum protection.



D Notched pin flat head
CLOU-16C | 16 mm
CLOU-19C | 19 mm



E Notched pin rounded head
CLOU16C-TB | 16 mm



F Notched pin black plastic head
CLOU16C-TPN | 16 mm

SPECIALIZED PINS

The ink pin secures clothing: if the shoplifter tries to pull the item, the ink frees indelible ink that makes it unusable and unsellable for the thief. It is very efficiently dissuasive and adds more protection for textiles of high value.

The alarm pin secures clothes against theft. When the shoplifter pulls it, that sets off the alarm, which alerts the store in a very efficient manner.

The Lanyard efficiently protects products such as handbags, shoes, bikes, rackets, etc. Its buckle allows not to pierce the products it protects.



G RF ink pin
CLOU-INK
Smooth pin 19 mm



H Red ink pin
CLOU-INKR
Smooth pin 16 mm



I Alarm pin
CLOU-ALARM
Audio alarm



J Lanyard 160 mm
LAN-1B
1 buckle 1 pin

ADJUSTABLE ANTI-THEFT DEVICE

The PeintureTag anti-theft device ideally protects cylindrical products of a 6 to 8,4cm diameter.

Its grip inside the collar prevents the product to slip. Ideal for painting sprays.



K PeintureTag
BBTAG-TRF | Cylindrical and adjustable tag

i Characteristics

- Adjustable anti-theft device
- Radiofrequency (8,2 MHz)
- Grip inside the collar to prevent the product from slipping
- Anti-vandalism pins

Bloc size (LxIxh):
33x33x37



Adjustable pull



EAS ACCESSORIES

ANTI-THEFT TAGS

ANTI-THEFT DEVICE FOR GLASSES

The anti-theft devices for glasses allow for an efficient protection without damaging the frame thanks to their adapted pads.



L Long glasses tag
RFLUNL | Pivotable RF
AMLUNL | Pivotable AM



M Glasses tag remover
DEVLUN | Screwdriver



N Short glasses tag black
RFLUNC | Compact RF
AMLUNC | Compact AM



O Short glasses tag gray
RFLUNC-G | Compact RF
AMLUNC-G | Compact AM

i Locking without damaging



	FORS Reference	Product Name	Size (mm) LxHxP	Technology	Color	Packing List	Package Weight
A	CLOU-16	Smooth pin flat head	16 mm	Depending on tag used	●	1 000	1,50 kg
	CLOU-19	Smooth pin flat head	19 mm	Depending on tag used	●	1 000	1,50 kg
B	CLOU16-TB	Smooth pin rounded head	16 mm	Depending on tag used	●	1 000	1,50 kg
C	CLOU16-TC	Smooth pin conical head	16 mm	Depending on tag used	●	1 000	1,50 kg
D	CLOU-16C	Notched pin flat head	16 mm	Depending on tag used	●	1 000	1,50 kg
	CLOU-19C	Notched pin flat head	19 mm	Depending on tag used	●	1 000	1,50 kg
E	CLOU16C-TB	Notched pin rounded head	16 mm	Depending on tag used	●	1 000	1,50 kg
F	CLOU16C-TPN	Notched pin black plastic head	16 mm	Depending on tag used	●	1 000	1,50 kg
G	CLOU-INK	RF ink pin	43x27x10	Depending on tag used	Colorless	100	0,70 kg
H	CLOU-INKR	Red ink pin	Ø 25x06	Depending on tag used	●	100	0,70 kg
I	CLOU-ALARM	Alarm pin	Ø 43x21,5	Depending on tag used	○	10	0,30 kg
J	LAN-1B	Lanyard	160 mm	Depending on tag used	●	1 000	2,5 kg
K	BBTAG-TRF	Cylindrical and adjustable tag	Ø 60 à 84 mm	RF	●	10	0,37 kg
L	RFLUNL	Long glasses tag	69x23	RF	●	50	0,50 kg
	AMLUNL	Long glasses tag	69x23	AM	●	50	0,50 kg
M	DEVLUN	Glasses tag remover			●	Unit	0,10 kg
N	RFLUNC	Short glasses tag black	23x30x25	RF	●	100	1,90 kg
N	AMLUNC	Short glasses tag black	23x30x25	AM	●	100	1,90 kg
O	RFLUNC-G	Short glasses tag gray	23x25x25	RF	●	100	1,60 kg
	AMLUNC-G	Short glasses tag gray	23x25x25	AM	●	100	1,60 kg

Best-sellers

Available security levels : see p. 59

Audio alarm



EAS ACCESSORIES

PROTECTION FOR BOTTLES AND LIQUORS

UNIVERSAL ALCOHOL FORSTAG

The Forstag alcohol was designed in order to facilitate putting and removing the anti-theft device at checkout, all the while adapting to all bottle types (wines, champagnes and liquors).



Its ergonomics allows optimum tightness and the Forstag Alcohol efficiently protects 99% of the bottles on the market.

FORSTAG
INNOVATIVE SOLUTIONS

NEW



A

FORS
exclusive
Patent

Forstag Alcohol
FTA | Universal
FTAC | Universal with
metal belt



B

FORS
exclusive
Patent

Forstag Alcohol with Top
FTAB | Universal with top
FTACB | Universal with top
and metal belt

i

An universal design



EASY AND QUICK

A perfect ergonomics for a quick and smooth set-up



SECURELY NOTCHED

Secured notches prevent from tool insertion in the cog



DENTED

For maximum grip on the bottle



METAL BELT

Integrated for maximum security



MAXIMUM DETECTION

RF or AM coil allowing maximal detection through the antennas





EAS ACCESSORIES

PROTECTION FOR BOTTLES AND LIQUORS

FORSTAG WINE & CHAMPAGNE

Because your wine and champagne shelves deserve a neat visual, we have developed discreet but efficient anti-theft devices.



C

FORS
exclusive
Patent

Forstag Vine

FTVIN | For wine only



FORSTAG
INNOVATIVE SOLUTIONS



One locking position only

The fixed locking principle guarantees the Forstag will be perfectly tight on the bottle.

Compact

No loss of space in shelves and in wine cases. The transparency of the wine and champagne Forstag makes it so the bottle's visual isn't altered.



D

FORS
exclusive
Patent

Forstag Champagne

FTCHA | For Champagne only



	FORS Reference	Product Name	Size (mm) W x H x D	Technology	Color	Packing List	Package Weight
A	FTA	Forstag Alcool	50 x 45 x 64 à 80	RF / AM    	 	100	3,00 kg
	FTAC	Forstag Alcool with metal belt	50 x 45 x 64 à 80	RF / AM    	 	100	3,00 kg
B	FTAB	Forstag Alcool with top	61 x 50 x 64 à 80	RF / AM    	 	100	4,50 kg
	FTACB	Forstag Alcool with top and belt	61 x 50 x 64 à 80	RF / AM    	 	100	4,50 kg
C	FTVIN	Forstag Vine	60 x 19 x 30	RF / AM    		100	1,90 kg
D	FTCHA	Forstag Champagne	60 x 19 x 30	RF / AM    		100	2,10 kg



Best-sellers



Available security levels : see p. 59



Audio alarm



EAS ACCESSORIES

PROTECTION FOR BOTTLES AND LIQUORS

COLFORS

The Colfors series represents a reinforced security solution for wine, champagne and liquor protection.



Colfors V1
CFV1 | Vines & Champagnes



Colfors V3
CFB3 | Small corks liquors



Colfors V4
CFG4 | Large corks liquors



Colfors V5
CFN5 | Jack' Daniel's only

STANDARD COLLAR

The universal bottle collar represents a simple and universal solution.



RF bottle collar
RFCOL | Universal



AM bottle collar
AMCOL | Universal



EAS ACCESSORIES

ANTI-THEFT DEVICES FOR FOOD

SAFRAN OR CAVIAR PROTECTION

Safran and caviar can be sold in a blister pack with our new blister case.



FORS
exclusive
Patent

G Blister case
USB | Safran

i **FORSTAG**
INNOVATIVE SOLUTIONS
For more information on the case, see [p. 72](#)

BASKETS PROTECTION



H Protect food
PFT | Protection of meat in basket, smoked salmon...



	FORS Reference	Product Name	Size (mm) WxHxD	Technology	Color	Packing List	Package Weight
A	CFWV1	Colfors V1 (Vines & Champagnes)	55x50x55	RF / EM Trigger 2P : with two protection points.		100	12,70 kg
B	CFBV3	Colfors V3 (Small corks liquors)	50x55x50			100	12,70 kg
C	CFGV4	Colfors V4 (Large corks liquors)	50x55x50			100	12,70 kg
D	CFNV5	Colfors V5 (Jack Daniel's only)	50x55x50			50	6,60 kg
E	RFCOL	Universal bottle collar	40x10x40	RF		100	1,90 kg
F	AMCOL	Universal bottle collar	36x33x30	AM		100	1,90 kg
G	USB	USB blister case	Open on 3 sides	RF / AM	-	125	7,00 kg
H	PFT	Protect food	67x40	RF / AM		100	2,10 kg

Best-sellers
 Available security levels : see p. 59
 Audio alarm



EAS ACCESSORIES

ANTI-THEFT DEVICES FOR FOOD

CANS

can-tag™ 1, 2 and 4

Because they are in high demand, energy and/or alcoholic drinks in cans suffer more and more from shoplifting.

The Faraday cage effect linked to the aluminium metal on RF and AM labels makes it impossible to detect these products with EAS systems at checkout.

With the can-tag™ 1, 2 and 4, Fors offers an efficient, fitting and economical solution.



The amortization of the investment in the CAN-TAG is guaranteed:

- By eradicating the growing phenomenon of in-store consuming
- By suppressing self-service cans shoplifting



Return on investment guaranteed in less than three months:

Return on investment on can-tag in an 800 sq meters store:

- Purchase of 1000 can-tags per 1,35 EUR before tax = 1350 EUR before tax
- Monthly losses for cans: beers, energy drinks, premix: 700 EUR before tax per month = 29 EUR before tax daily
- Amount of protected cans sold per day: 120 units
- Putting-on 120 can-tags: 6 seconds x 120 units = 12mn per day

Break-even point with a 5 year amortization rate:

- Investment amortization:
 $1350 \text{ EUR} / 60 \text{ months} / 25 \text{ working days} = 0,90 \text{ EUR}$
- Workforce cost for 12 minutes:
 $16 \text{ EUR} / 60 \text{ mn} * 12 \text{ mn} = 3,20 \text{ EUR}$
- Daily savings with can-tag: 24,90 EUR
- Break-even point: $1350 / 24,90 = 55 \text{ exploitation days ie } 2,16 \text{ months.}$



EAS ACCESSORIES

ANTI-THEFT DEVICES FOR FOOD



FORS
exclusive
Patent

A CAN-TAG™ 1
CT1 | For 25 cl cans



FORS
exclusive
Patent

B CAN-TAG™ 2
CT2 | For 33 and 50 cl cans



FORS
exclusive
Patent

C CAN-TAG™ 4
CT4 | For Redbull cans
of 47 and 59 cl

BOÎTE DE CRABE

can-tag™ 3

Because they are in high demand, crab products suffer more and more from shoplifting.

The Faraday cage effect linked to the aluminium metal on RF and AM labels makes it impossible to detect these products with EAS systems at checkout.

With the Can-tag™ 1, 2 and 4, Fors offers an efficient, fitting and economical solution.

FORSTAG
INNOVATIVE SOLUTIONS



FORS
exclusive
Patent

D CAN-TAG™ 3
CT3 | For CHATKA crab boxes



i STACKABLE



	FORS Reference	Product Name	Size (mm) WxHxD	Technology	Color	Packing List	Package Weight		
	A	CT1	CAN-TAG™ 1 - 25 cl	29xØ55	RF / AM		●	100	4,60 kg
	B	CT2	CAN-TAG™ 2 - 33 & 50 cl	29xØ59	RF / AM		●	100	4,80 kg
	C	CT4	CAN-TAG™ 4 - 47 & 59 cl	29xØ64	RF / AM		●	300	14,50 kg
	D	CT3	CAN-TAG™ 3	33xØ89	RF / AM		●	100	8,50 kg
Best-sellers		Available security levels : see p. 59			Audio alarm				



EAS ACCESSORIES

SPIDERS AND ALARM-EQUIPPED DEVICES

SPIDERS

The spiders are specially adapted to bulky and high added value products.

They benefit from an RF and AM ferrite and a 95 dB alarm



Mini spider
SPIDERMINI | Small Spider



Black spider 2 alarms
SPIDER | Large Spider

NET SPIDER

The net spiders are the ideal solution for the protection of fragile products such as tablets and video games.

The 95 dB alarm sets off if the net cable is cut off.



Net spider
SPIDERFIL | For compact products



Middle net spider
SPIDERBOT | For tablets and bottles



Console net spider
SPIDERCON | Perfect for gaming consoles



EAS ACCESSORIES

SPIDERS AND ALARM-EQUIPPED DEVICES

ALARM-EQUIPPED ANTI-THEFT DEVICES

With its 3 alarms, the alarm cable can protect leather goods, clothes, drillers, bikes...

Either cutting the cable or passing the anti-theft device through the security gates will set off the inbuilt alarm.

This alarm won't stop until the product is unlocked.

























Alarm cable 175mm
CABAL-175 | 3 Alarms



Alarm cable 1200mm
CABAL-1200 | 3 Alarms



	FORS Reference	Product Name	Size (mm) WxHxD	Technology	Color	Packing List	Package Weight
A	SPIDERMINI	Mini spider	Ø 45 mm	RF / AM    		50	2,05 kg
B	SPIDER	Black spider 2 Alarms	Ø 70 mm	RF / AM    		50	5,50 kg
C	SPIDERFIL	Net spider	280x100x100	RF    		50	4,35 kg
D	SPIDERBOT	Middle net spider	400x140x140	RF    		10	1,10 kg
E	SPIDERCON	Console net spider	480x340x110	RF / AM    		10	1,20 kg
F	CABAL-175	3 alarms cable	175 mm	RF / AM    		10	0,40 kg
G	CABAL-1200	3 alarms cable	1200 mm	RF / AM    		10	0,44 kg

  Best-sellers
   Available security levels: see p. 59
 Audio alarm



EAS ACCESSORIES

SPINDLES PROTECTION

SPINDLES PROTECTION

Prevent your products displayed on spindles from being stolen thanks to the BlisterKey and Verrou Broche devices.

Equipped with a manual deactivator, the staff will be able to hand the product to the client very swiftly.



A VERROU-B
Spindle protection (lock)
Spindle Ø 4 mm



B VERROU-N
Spindle protection (lock)
Spindle Ø 5 mm



C VERROU-G
Spindle protection (lock)
Spindle Ø 8 mm



D BK
Blisterkey



E DEV-VERROU
Portable deactivator
For spindle protection A, B and C



FORSTAG
INNOVATIVE SOLUTIONS

The Forstag padlock protects spindles more securely, for more information please see page 45.



	FORS Reference	Product Name	Size (mm) WxHxD	Technology	Color	Packing List	Package Weight
A	VERROU-B	Spindle protection Ø 4 mm	38x19x15		○	10	0,01 kg
B	VERROU-N	Spindle protection Ø 5 mm	38x19x15		●	10	0,01 kg
C	VERROU-G	Spindle protection Ø 8 mm	38x19x15		●	10	0,01 kg
D	BK	Blisterkey	44x25x11,5		●	50	0,80 kg
E	DEV-VERROU	Portable deactivator for spindle protection	Ø 20x57 mm		●	unit	0,15 kg

Available security levels : see p. 59 Audio alarm



EAS ACCESSORIES

REMOVERS

TAG REMOVERS

This series of deactivators ensures the unlocking of all of our anti-theft devices that have one security point.

Because shoplifting with magnets is becoming increasingly common, magnetic power must be stronger in order to secure your accessories.



A Textile deactivator
DEV-TEX | Textile opening



B SuperLock deactivator
DEV-SL | SuperLock opening



C HyperLock deactivator
DEV-HL | HyperLock opening

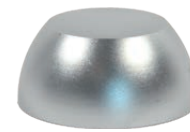

D Golf deactivator
DEV-GOLF | Golf opening



E BlueBox deactivator
DEV-BB | BlueBox opening

i 3 magnetic power levels

Textile: 5000 Gauss
 SuperLock: 12000 Gauss
 HyperLock: 16000 Gauss

CASE REMOVERS

This series of deactivators ensures the unlocking of all of our anti-theft cases. Our patented opening system for shells has 1 to 4 security points so as to efficiently prevent shoplifting.



G Grey Fors deactivator
DEV-FORSG | Fors opening (lock not provided)



H Red Fors deactivator
DEV-FORSR | Fors opening



F 5-4 deactivator
DEV-54C | Textile, Fors, 3P and 4P opening



I Manuel Fors deactivator
S704 | Fors, 2P opening



Our universal 5-4 deactivator secures in an optimal way our cases.

It also has an embedded textile deactivator for accessories.

We provide the deactivator with a lockable protection cap

	FORS Reference	Product Name	Size (mm) WxHxD	Technology	Case Security levels	Color	Packing List	Package Weight
A	DEV-TEX	Textile deactivator	Ø 61 mm	Textile		●	unit	0,20 kg
B	DEV-SL	SuperLock deactivator	Ø 74x45	SuperLock		●	unit	0,50 kg
C	DEV-HL	HyperLock deactivator	Ø 82x62	HyperLock		●	unit	1,70 kg
D	DEV-GOLF	Golf deactivator	Ø 75 x 35	Golf tag		●	unit	0,50 kg
E	DEV-BB	BlueBox deactivator	Ø 74 x 50	BlueBox		●	unit	1,70 kg
F	DEV-54C	Universal 5-4 deactivator	166 x 46 x 49	Textile	Fors, 3P, 4P	●	unit	0,40 kg
G	DEV-FORSG	Grey Fors deactivator	93 x 40 x 26		Fors	●	unit	0,07 kg
H	DEV-FORSR	Red Fors deactivator	93 x 40 x 26		Fors	●	unit	0,07 kg
I	S704	Manual Fors deactivator	100 x 42 x 45		Fors, 2P	●	unit	0,108 kg

Best-sellers
 Magnetic power
 Case security levels
 Opening alarmed case

PROTECTION CASES

THE CONCEPT BEHIND FORS CASES

ANTI-SCRATCH PICOTS

Allows to stack cases and avoid scratching them.



FOLDING HOOK

Minimal height: no room loss or risk to lose the hook

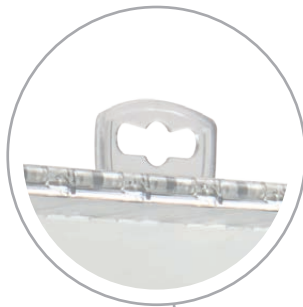

NO METALLIC AXIS

Reinforced cases solidity at the hinge.



REINFORCED SIDES



TRIGGER 4P WITH OPTIONAL ALARM



For maximum security



REINFORCED SECURITY

Possibility to stick the detection labels (RF and AM).

POLYCARBONATE L121-R

High resistance and total transparency. Anti UV protection.

TRIGGER 3P (PATENTED)



3 points of protection with embedded RF or AM ferrite.

OTHER TRIGGERS

Light triggers are also available:



Trigger 2P: with 2 protection points.



Trigger 1P: with 1 protection point.

— 4 levels of security —



- Options with alarm and case customization 62
- Video games :
 - Playstation 64
 - Nintendo 66
 - Xbox 68
 - Generic cases 69
- IT :
 - Apple 70
 - Tablets and readers 71
 - Storage (hard drive, USB stick, etc.) 72
 - Gaming accessories (mouse, headsets, etc.) 74
- Connected objects : 75
- TV, photos et sound :
 - Connected TV boxes and cameras 76
 - Headsets, headphones, speakers 77
- Telecom : 78
- Batteries : 79
- DPH universe : 80
- Cosmetics : 82

*The diverse offer in our cases series
allows you to protect all types of products.*

You have a specific product that is not listed here ?

We can help you !

With your product's dimensions, go page 82 where a life-size guide becomes the perfect tool to find the most efficient solution for your case.

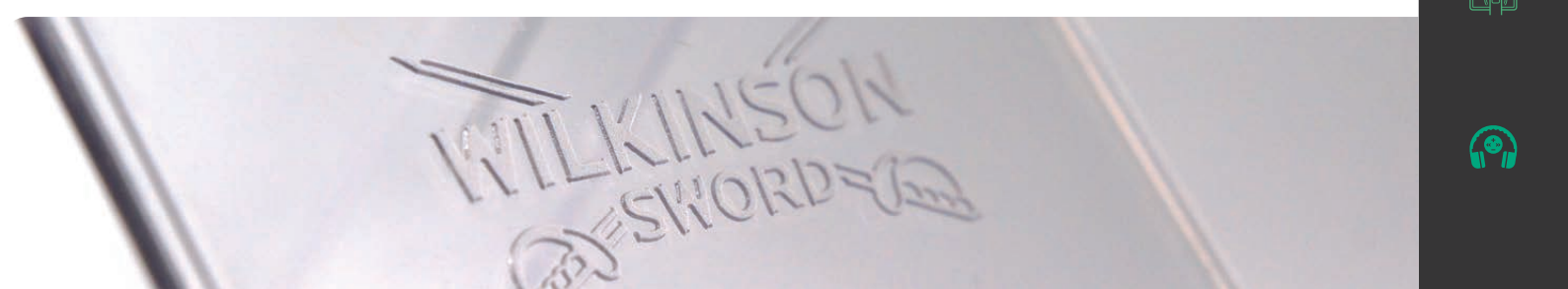



PROTECTION CASES

ALARM CASES



ALARM CASES

A level of security never reached before !

ROBUSTNESS AND SECURITY

The alarm trigger has **4 points of protection**: 3 for locking and 1 as an alarm system, unreachable, allowing maximum security for the protected products.

An RF (radio frequency) or AM (magneto acoustic) ferrite is embedded. You can also stick 75mm EM (electro magnetic) labels inside the case.

Any fraudulent opening of the case instantly sets off the alarm, which alerts the personnel.

The alarm trigger detects the presence of magnets. If a magnet is brought close to it, the alarm sets off after 3 seconds, for a duration of 10 seconds, which alerts the staff on a possible shoplifting attempt.

This buffer time allows the staff to deactivate the case without triggering the alarm too soon.

The 4P deactivator opens the case and simultaneously deactivates the alarm system.

SIMPLE TO USE :

The locking and activation of the alarm are done by pressing both buttons on the trigger.

Thanks to the Fors 4P deactivator, the deactivation of the alarm is easier at checkout for the staff: **it only takes one move.**

The light goes on when the alarm is activated and then blinks.

Takes **minimum space**: the trigger alarm doesn't take more space than any other type of trigger. Must take into account that the available height inside the case is reduced by 13mm.

Alarm triggers are **reusable**.

FEATURES

- Trigger material: polycarbonate (very resistant)
- Alarm 95 dB
- Replaceable battery: CR 2450
- Battery life: 3 years active (without an alarm)
- Battery life with activated alarm: around 3 days
- Resists tough environments: cold, water drops, etc.

MODELS & STANDARDS

- Patented Locking system
- RoHS compliant
- CE Certification

ADAPTABILITY

The alarm trigger adapts to a large amount of Fors cases.

You can replace old triggers on your cases with these ones.



This pictogram allows you to easily see which cases have the alarm option.

The essential solution to protect your products against shoplifting



Trigger alarm V3



Trigger alarm V2



5-4 deactivator

TO CLOSE THE CASE

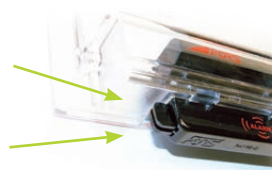

To close the case, press both buttons simultaneously. You will hear a beep and the light will go on, confirming the alarm is activated.

TO OPEN THE CASE



To unlock the case, insert it in the deactivator following the indications on the picture.



PROTECTION CASES

CASE CUSTOMIZATION

CASE CUSTOMIZATION

Many benefits !



Official cases for BIC and Philips
Available immediately



Label with your logo



Engraving



Customized design and colors

MAKE YOUR PRESENTATION MORE IMPACTFUL

Customers easily identify the products in the store.

Creation of universes in stores making the merchandising policy more impactful.

The products are valorized and this triggers the buying process.

Cases will not be mixed and each stays in its zone.



Many brands and stores have been trusting us for years.

Our cases are part of the merchandising policy and are landmarks for customers and staff in the store

Exclusive design, customized colors, labels with logos, engravings...

Everything is possible !



PROTECTION CASES

VIDEO GAMES



SONY

Official partner

Fors is the **official supplier** for Sony for 25 years.

Our cases' **strong visual identity enhances the merchandising** and allows for a quick identification of the games depending on the video games console.



A PS4 game
Case : PS4
Official PS4 case



B PS3 game
Case : PS3
Official PS3 case



C PS Vita game
Case : PSVITA
Official PS Vita case



D PSP game 1
Case : PSP1
Official PSP case



E PSP game 2
Case : PSP2
Official PSP case

CONSOLES AND PACKAGES

Playstation video games are sizeable products with high added value.

The format of these products doesn't allow for cases.

Our spider and net spider for video games are equipped with an RF and AM ferrite and an alarm 95dB. They set off if the cable is cut off: it is the optimum solution.

These products need to include protection before they are put on display in self-service.

However, two accessories match depending on the desired level of protection :

More information on the spiders: see p. 56.



Spidercon
Console net spider



Spider
Large spider



F PSP console
Case : PSPC
Official PSP case



G PS Vita console
Case : CDR
Official PS Vita case



PROTECTION CASES

VIDEO GAMES

CONTROLLERS AND ACCESSORIES

Highly sought after, the SONY accessories must be protected. We recommend the use of cases adapted to the dimensions of the product or the Spider (p.56).

For any other accessory, please see the guide p. 86.



Official Dualshock 4 controller
Case : P22
Alternative : Spider



Hori controller: Tactical assault commander pro type M2
Case : P14
Alternative : Spider



Headset
Case : P22
Alternative : Spider



Playstation camera
Case : T03
Alternative : P22, Spider



Gift card, Subscription card
Case : USB
Alternative : CDP

	FORS Reference	Product Name	Code engraved on the case	Volume (cm ³)	Internal size (mm) W x H x D	External size (mm) W x H x D	Blister Slot	Security Levels	Packing List	Package Weight
A	PS4	PS4 game	344	458	140x172x19	148x24x24			50	13,20 kg
B	PS3	PS3 game	333	477	138x173x20	148x240x32			50	13,80 kg
C	PSVITA	PS Vita game	341A	250	109x135x17	148x240x32			50	8,70 kg
D	PSP1	PSP game 1	327abc	355	105x188x18	120x285/255x28			75	18,00 kg
E	PSP2	PSP game 2	328	671	105x188x34	120x285/255x42			63	15,20 kg
F	PSPC	PSP console	329	4074	236x137x126	258x178x131			9	6,20 kg
G	CDR	PS Vita console	112	4094	285x228x63	292x258x68			10	6,70 kg
H	P22	P22 case	322	3600	200x200x90	210x230x97			10	6,50 kg
I	T03	T03 case	348	2831	150x222x85	154x256x90			14	5,56 kg
J	P14	P14 case	314	7353	230x296x108	242x331x115			5	5,10 kg
K	USB	Blister case	345	80	70x72x16	76x104x28	3 sides		125	9,00 kg
	CDP	Full CD	106	285	144x132x15	153x163x21			84	14,60 kg

Best-sellers



Available security levels: see p.60



Optional alarmed protection: see p.62



PROTECTION CASES

VIDEO GAMES

ANTI-THEFT SOLUTIONS | FORS



NINTENDO

Official partner

Fors is the **official supplier** for Nintendo for 25 years.

Our cases' **strong visual identity** enhances the **merchandising** and allows for a quick identification of the games depending on the video games console.



A Switch game
Case : SW1
Official Switch case



B Wii U game
Case : WIU
Official Wii U case



C DS game
Case : DSJ
Official DS case



D Game light
Case : DSJL
DS game format

CONSOLES AND PACKAGES

Switch and Wii U consoles by Nintendo are sizeable products with high added value. These products need to include protection before they are put on display in self-service.



The format of these products doesn't allow for cases. However, the spiders are well adapted. **For more informations on Spiders : See p. 56.**



Spider
Large spider



Spidermini
Small spider



Spidercon
Console net spider

E



DSi console
Official DSi case
Alternatives : Spider, Mini-Spider

F



DS console
Official DS case
Alternatives : Spider, Mini-Spider

G



3DS console
Official 3DS case
Alternatives : Spider, Mini-Spider

H



3DS XL console
Official 3DS XL case
Alternatives : Spider, Mini-Spider



PROTECTION CASES

VIDEO GAMES

ANTI-THEFT SOLUTIONS | FORS

CONTROLLERS AND ACCESSORIES

Nintendo accessories are products with a high markup. They need to include protection before they are put on display. We recommend to use the cases adapted to the dimensions of the product or Spiders (p.56).

For any other accessory, please see the guide p. 86.



I Nintendo Switch dock set
Case : P26
Alternative : Spider



J Joy-Con
Case : LAM 05
Alternative : Mini-Spider



K Nintendo Switch Controller Joy-Con charging grip
Case : Print - P12
Alternative : Spider



M Joy-Con pair
Case : P08
Alternative : Mini-Spider



L Pokéball Plus
Case : COS5
Alternative : Mini-Spider

	FORS Reference	Product Name	Code engraved on the case	Volume (cm ³)	Internal size (mm) W x H x D	External size (mm) W x H x D	Blister Slot	Security Levels	Packing List	Package Weight
	A	SW1	Switch game	346	534	175x110x18	205x118x22		20	3,20 kg
	B	WIIU	Wii U game	332	534	139x192x20	147x252x27		50	13,30 kg
	C	DSJ	DS game	325	399	144x132x21	153x163x29		20	3,10 kg
	D	DSJL	light game	337	375	142x132x20	151x166x27		20	3,80 kg
	E	DSI	DSi console	336	1785	257x124x56	264x185x64		17	6,30 kg
	F	DSC	DS console	326	2411	224x156x69	234x190x76		14	6,30 kg
	G	C3DS	3DS console	339	3988	233x163x105	246x220x109		7	4,50 kg
	H	3DSXL	3DS XL console	342	1516	190x133x60	204x172x65		16	5,40 kg
	I	P26	P26 case	326	3626	200x259x70	221x298x78		10	7,40 kg
	J	LAM05	LAM 05 case	412*	495	96x112x46	102x145x52		30	4,80 kg
K	PRINT	Printer case	207	1704	183x133x70	192x205x76			26	8,50 kg
	P12	P12 case	309	701	99x118x60	110x151x71	1 side		40	8,70 kg
L	COS5	COS 5 case	501	352	70x70x72	85x94x94			80	10,00 kg
M	P08	P08 case	308	847	128x135x49	139x166x60	1 side		40	9,90 kg

Best-sellers

Security levels: See p. 60 See p. 59

Optional alarmed protection : see p.62



PROTECTION CASES

VIDEO GAMES



MICROSOFT

Official partner

Fors is the **official supplier** for Microsoft for 25 years.

Our cases' **strong visual identity** enhances the **merchandising** and allows for a quick identification of the games depending on the video games console.

CONSOLES AND PACKAGES

Xbox consoles by Microsoft are sizeable products with high added value. These products need to include protection before they are

put on display in self-service. The format of these products doesn't allow for cases. However, **the spiders are well adapted**: see p. 56.



A Jeu Xbox One
Case : XBONE
Official Xbox One case

B Jeu Xbox 360
Case : XB360
Official Xbox 360 case



- Spider
Large spider
- Spidercon
Console net spider

MANETTES ET ACCESSOIRES

Nintendo accessories are products with a high markup.

We recommend to use the **cases adapted to the dimensions** of the product or **Spiders** (p.56).

For any other accessory, please see the guide p. 86.



C
Xbox wireless controller
Case : P22
Alternatives : Spider, Net spider



D
Xbox headset : Stealth 600
Case : P27
Alternatives : Spider, Net spider



E
Windows 8
Case : P27
Alternatives : Spider, Net spider

FORS Reference	Product Name	Code engraved on the case	Volume (cm ³)	Internal size (mm) W x H x D	External size (mm) W x H x D	Blister Slot	Security Levels	Packing List	Package Weight
A	XBONE	XBOX ONE game	343	451	138x172x19	148x231x24		55	13,10 kg
B	XB360	XBOX 360 game	213	613	143x195x22	154x250x29		50	14,00 kg
C	P22	P22 case	322	3600	200x200x90	210x230x97		10	6,50 kg
D	P27	P27 case	327	5159	198x258x101	212x298x106		6	5,20 kg
E	WIN8	Windows 8 case	342	444	149x149x20	157,5x181x27		20	3,70 kg

Best-sellers

Available security levels : see p.60

Optional alarmed protection : see p.62



PROTECTION CASES

GENERIC PRODUCTS

GENERIC PRODUCTS

Generic cases represent a more economical solution to protect your video games.

HD DVD and light DVD cases include the Fors innovations. The metallic axis were replaced by plastic picots in unbreakable polycarbonate.



A Blu-Ray
DVHD | 1 Blu-Ray format



B DVD light
DVDL | 1 DVD format



C CD 3
CD3 | 1CD opened case



D CD full
CDP | 1CD full case



E CD / Game light
DSJL | Double CD case



F DVD full
DVDP | 1 DVD format



G Double DVD
DVD2 | 2 DVD format



H Triple Blu-Ray
DVHD3 | 3 Blu-Ray format

	FORS Reference	Product Name	Code engraved on the case	Volume (cm ³)	Internal size (mm) W x H x D	External size (mm) W x H x D	Blister Slot	Security Levels	Packing List	Package Weight
	A	Blu-Ray	117A	430	139x172x18	153x230x23		🔒 📀 🔔	65	15,40 kg
	B	DVD light	119	475	144x194x17	150x228x21		🔒 📀 🔔	50	9,10 kg
	C	CD 3	104	213	141x126x12	154x145x16		🔒 📀 📀 🔔	50	3,50 kg
	D	CD full	106	285	144x132x15	153x163x21		🔒 📀 🔔	84	14,60 kg
	E	CD / Game light	337	375	142x132x20	151x166x27		🔒 📀 📀 🔔	20	3,80 kg
	F	DVD full	111	558	143x195x20	153x230x25		🔒 📀 🔔	65	15,60 kg
	G	Double DVD	113	1313	143x204x45	153x236x50		🔒 📀 📀 🔔	25	7,00 kg
	H	Triple Blu-Ray	117B	1071	137x170x46	149x208x51		🔒 📀 📀 🔔	30	8,00 kg

● Best-sellers



Available security levels: see p.60



Optional alarmed protection: see p.62



PROTECTION CASES

IT

APPLE PRODUCTS

Please see our selection of devices adapted to Apple products. Due to their high specificity however, we recommend that we get in touch with our team for a specific analysis.

Do not hesitate to consult with us.

Spider
Large spider

Spidercon
Console net spider



The other Apple products such as Macbook, Air, Pro, keyboards or iMac are sizeable products with a high added value that need to include protection before they are put on display in self-service.

All the formats of these products do not allow to integrate a protection case, however the spiders fit well. **For more information on spiders: see p. 56.**

A
Apple Magic Trakpad
Case : DVHD



B
Apple Magic Mouse
Case : P08



C
Apple USB-C power adapter
Case : DVD2



Apple Ipad
See tablets on the next page

Apple Watch
See connected objects solutions p.75

Apple Iphone
See mobile phones solutions p. 78



E
Apple MagSafe 1 & 2 power adapter
Case : P22 - T03



D
Apple Pencil
Case : P29



	FORS Reference	Product Name	Code engraved on the case	Volume (cm ³)	Internal size (mm) W x H x D	External size (mm) W x H x D	Blister Slot	Security Levels	Packing List	Package Weight
	A	DVHD	117A	430	139x172x18	153x230x23			65	15,40 kg
	B	P08	308	847	128x135x49	139x166x60	1 side		40	9,90 kg
	C	P29	335	432	58x218x34	69x254x40			28	4,40 kg
	D	DVD2	113	1313	143x204x45	153x236x50			25	7,00 kg
	E	P22	322	3600	200x200x90	210x230x97			10	6,50 kg
		T03	348	2831	150x222x85	154x256x90			14	5,56 kg

Best-sellers



Available security levels : see p.60



Optional alarmed protection : see p.62



PROTECTION CASES

IT

TABLETS



Middle net spider
SPIDERBOT

We have selected for you our cases that best fit for the majority of tablets, but as the shapes and sizes are very diverse, there are atypical models.

You can then refer to our guide on p.86 to see which cases are the best fit, or decide for a **spider** or a **net spider** (p.56). For **touch display solutions**: see p. 88.



A 7 inches tablets
Case: T03



B 10 inches tablets
Case: P26 | Ipad Air format
P27 | Deeper
P14 | Higher



C 12 inches tablets
Case: P14

READERS



If all the different models of readers each have their specificities, their formats remain very similar.

And if not, you can refer to our guide on p.86 to see which cases are the best fit, or decide for a **spider** or a **net spider** (p.56).

The T03 case covers the majority of them.



A Kindle, Kobo and classic readers
Case: T03



B Kindle Oasis, Kobo Forma and large readers
Case: P26



D Small readers
Case: DVD2

	FORS Reference	Product Name	Code engraved on the case	Volume (cm ³)	Internal size (mm) WxHxD	External size (mm) WxHxD	Blister Slot	Security Levels	Packing List	Package Weight
A	T03	T03 case	348	2831	150x222x85	154x256x90			14	5,56 kg
B	P26	P26 case	326	3626	200x259x70	221x298x78			10	7,40 kg
	P27	P27 case	327	5159	198x258x101	212x298x106			6	5,20 kg
C	P14	P14 case	314	7353	230x296x108	242x331x115			5	5,10 kg
D	DVD2	Double DVD	113	1313	143x204x45	153x236x50			25	7,00 kg

Best-sellers

Available security levels: see p.60

Optional alarmed protection: see p.62



PROTECTION CASES

IT

MEMORY STICKS USB STICKS

The new blister case saves up to 50% in space compared to a traditional case.

Compact and smart, this case allows to protect the whole shelf.



A

USB and memory sticks
Case: USB

FORS
exclusive
Patent

Unique
&
slick design

No waste
of
space

Better
valorization
of your
products

i

- Saving up to 50% in space
- Saving time
- The blister can stick out of the case on three sides
- Allows to use the blister's hook
- Does not need any modification of your shelves
- One case only for all of your USB and memory sticks



FORSTAG
INNOVATIVE SOLUTIONS



PROTECTION CASES

IT

HARD DRIVES



We have selected for you our cases that best fit for the majority of hard drives, but as the shapes and sizes are very diverse, there are atypical models.

You can then refer to our guide on p.86 to see which cases are the best fit, or decide for a spider or net spider. **For more informations on spiders: See p. 56.**



B 2,5 inches hard drives
Case: DVHD3 | Triple Blu-Ray format
DVD2 | Higher

C 3,5 inches hard drives
Case: T03



 **Mini Spider**
SPIDERMINI | Small spider



 **Middle net spider**
SPIDERBOT | Small net spider

	FORS Reference	Product Name	Code engraved on the case	Volume (cm ³)	Internal size (mm) WxHxD	External size (mm) WxHxD	Blister Slot	Security Levels	Packing List	Package Weight
A	USB	Blister case	345	80	70x72x16	76x104x28	3 sides		125	9,00 kg
B	DVHD3	Triple Blu-Ray	117B	1071	137x170x46	149x208x51			30	8,00 kg
	DVD2	Double DVD	113	1313	143x204x45	153x236x50			25	7,00 kg
C	T03	T03 case	348	2831	150x222x85	154x256x90			14	5,56 kg

  Best-sellers

Security levels:  See p. 60  See p. 59

 Optional alarmed protection : see p.62



PROTECTION CASES

IT

GAMING ACCESSORIES

Gaming accessories must be protected. For this we can use cases adapted to their dimensions or use another accessory : The spider (p. 56).

For any other accessory, you can see the guide p. 86.



A Gaming headset

Case: P22 | 20 x 20 x 9 cm format
P14 - P26 - P27 | Higher
P14D - P15 | Deeper



B Gaming mouse

Case: DVD2 | Double DVD format
T03 | Deeper
P22 | Wider



 Spider
Large spider

 Spidercon
Console net spider



PROTECTION CASES

CONNECTED OBJECTS

CONNECTED OBJECTS



Gaming accessories must be protected.

For any other accessory, you can see the guide p. 86.

For this we can use cases adapted to their dimensions or use another accessory: the Spider (p. 56).

For touch display solutions for watches : p. 97.



Connected watches and bracelets

Case: DVD2 | Double DVD format
T03 | Deeper
P29 | Long format



Spider
Large spider



Spidermini
Small spider

	FORS Reference	Product Name	Code engraved on the case	Volume (cm ³)	Internal size (mm) WxHxD	External size (mm) WxHxD	Blister Slot	Security Levels	Packing List	Package Weight
A	P14	P14 case	314	7353	230x296x108	242x331x115		🔒🔒🔒🔊	5	5,10 kg
	P14D	Double P14 case	334	13787	227x292x208	242x331x216		🔒🔒🔒🔊	2	2,8 kg
	P15	P15 case	315	10249	227x215x210	240x260x215		🔒🔒🔒🔊	2	2,30 kg
	P26	P26 case	326	3626	200x259x70	221x298x78		🔒🔒🔒🔊	10	7,40 kg
	P27	P27 case	327	5 159	198x258x101	212x298x106		🔒🔒🔒🔊	6	5,20 kg
A/B	P22	P22 case	322	3600	200x200x90	210x230x97		🔒🔒🔒🔊	10	6,50 kg
B	DVD2	Double DVD	113	1313	143x204x45	153x236x50		🔒🔒🔒🔊	25	7,00 kg
B/C	T03	T03 case	348	2831	150x222x85	154x256x90		🔒🔒🔒🔊	14	5,56 kg
C	P29	P29 case	335	432	58x218x34	69x254x40		🔒🔒🔒🔊	28	4,40 kg

● Best-sellers



Available security levels: see p.60



Optional alarmed protection : see p.62



PROTECTION CASES

MULTIMEDIA

TV ACCESSORIES



Increasingly present in our homes, connected TV accessories are coveted products.

Our cases will protect them efficiently.



Chromecast 3

Case: P08

Alternative: Mini-Spider



Chromecast Ultra

Case: P08

Alternative: Mini-Spider



Apple TV 4K

Case: T03

Alternative: Mini-Spider



Android TV Nvidia

Case: P14D

Alternative: Spider

CAMERAS



Our camera cases are adapted for compact cameras as well as hybrids and reflex.

For touch display solutions: voir p. 88.



Compact cameras

Case: T03

Alternative: Mini-Spider



Large cameras

Case: P22 | 20x20x9 cm format

P14 - P26 - P27 | Higher

P14D - P15 | Deeper

Alternative: Spider

	FORS Reference	Product Name	Code on the case	Volume (cm ³)	Internal size (mm) WxHxD	External size (mm) WxHxD	Blister Slot	Security Levels	Packing List	Package Weight
A	P08	P08 case	308	847	128x135x49	139x166x60	1 side		40	9,90 kg
B	T03	T03 case	348	2831	150x222x85	154x256x90			14	5,56 kg
C	P14	P14 case	314	7353	230x296x108	242x331x115			5	5,10 kg
	P14D	Double P14 case	334	13787	227x292x208	242x331x216			2	2,80 kg
	P15	P15 case	315	10249	227x215x210	240x260x215			2	2,30 kg

Best-sellers

Security levels: See p. 60

See p. 59

Optional alarmed protection: see p.62



PROTECTION CASES

MULTIMEDIA

AUDIO

Our cases will meet your needs in terms of protection for headsets, headphones and speakers.

For touch display solutions: see p. 96



C Headsets

Case: P22 | 20x20x9 cm format
P14 - P26 - P27 | Higher
P14D - P15 | Deeper
Alternative: Spider et net spider



D Headphones

Case: LAM7 | Thin square
P17 | Higher
P10 | Wider



E Speakers

Case: COS5 | 7 cm cube
P17 | Higher
P22 - T03 | Wider

	FORS Reference	Product Name	Code on the case	Volume (cm ³)	Internal size (mm) WxHxD	External size (mm) WxHxD	Blister Slot	Security Levels	Packing List	Package Weight
C	P22	P22 case	322	3600	200x200x90	210x230x97		🔒 📦 🎧	10	6,50 kg
	P26	P26 case	326	3626	200x259x70	221x298x78		🔒 📦 🎧	10	7,40 kg
	P27	P27 case	327	5159	198x258x101	212x298x106		🔒 📦 🎧	6	5,20 kg
D	LAM07	LAM 07 case	416*	286	99x111x26	102x145x32		🔒 📦 🎧	48	5,10 kg
	P17	P17 case	317*	970	101x196x49	113x228x55	1 side	🔒 📦 🎧	49	12,10 kg
	P10	P10 case	310	1340	143x218x43	153x258x49	1 side	🔒 📦 🎧	25	9,20 kg
E	COS5	COS 5 case	501	352	70x70x72	85x94x94		🔒 📦 🎧	80	10,00 kg

● Best-sellers

Security levels: 🔒 See p. 60 📦 📦 📦 See p. 59

🎧 Optional alarmed protection: see p.62



PROTECTION CASES

TELECOM

MOBILE PHONES AND GPS

The success of high end smart-phones makes them highly coveted products that need an

appropriate protection. These cases will efficiently protect them.



To secure your mobile phone displays in self-service : [see the touch display section p.88.](#)



Small mobile phones
Case: P17 | Tall
P17D | Deeper
Alternative : Mini-spider



Mobile phones
Case: T03 | Ideal for smartphones
P10 | Less deep
C3DTEL | Deeper
P22 | Wider
Alternative : Spider et Mini-spider



GPS
Case: C3DTEL | Wide format
P22 | Higher
P15 | Deeper
P14 | Large format
P14D | Large and deep
Alternative : Spider et net spider



i T01 case
The new case for phone cases protects 80% of the presentation.



Phone cases
Case : T01
Alternative : P17 - SW1 - DVDP - DVD2



Mobile phone accessories
Case: P17 | Tall
P17D | Deeper
T01 | Less deep
P13 | Less wide
P10 | Wider



PROTECTION CASES

BATTERIES

BATTERIES

Batteries packs being fragile and easily breakable, it is important to protect them with an adapted solution.

Fors offers a large choice of cases to cover the different sizes.

They are transparent so as your products and their characteristics remain visible.



F Button cell
Case: USB - LAM01

G LR3/LR6 batteries
Case: USB - VOLT - LAM02

H LR15/LR20 batteries
Case: LAM04 - LAM11

	FORS Reference	Product Name	Code on the case	Volume (cm ³)	Internal size (mm) W x H x D	External size (mm) W x H x D	Blister Slot	Security Levels	Packing List	Package Weight
A	P17	P17 case	317*	970	101 x 196 x 49	113 x 228 x 55	1 side		49	12,10 kg
	P17D	Double P17 case	317*	1 392	100 x 196 x 71	113 x 228 x 71	1 side		25	6,80 kg
B	T03	T03 case	348	2 831	150 x 222 x 85	154 x 256 x 90			14	5,56 kg
	P10	P10 case	310	1 340	143 x 218 x 43	153 x 258 x 49	1 side		25	9,20 kg
	C3DTEL	3D Tel case	339	3 988	233 x 163 x 105	246 x 220 x 109			7	4,50 kg
	P22	P22 case	322	3 600	200 x 200 x 90	210 x 230 x 97			10	6,50 kg
C	P14	P14 case	314	7 353	230 x 296 x 108	242 x 331 x 115			5	5,10 kg
	P14D	Double P14 case	334	13 787	227 x 292 x 208	242 x 331 x 216			2	2,80 kg
	P15	P15 case	315	10 249	227 x 215 x 210	240 x 260 x 215			2	2,30 kg
D	T01	T01 case	347A	563	112 x 201 x 25	120 x 234 x 30			50	9,95 kg
	SW1	Switch game case	346	346	175 x 110 x 18	205 x 118 x 22			20	3,20 kg
	DVDP	DVD full case	111	558	143 x 195 x 20	153 x 230 x 25			65	15,60 kg
	DVD2	Double DVD case	113	1 313	143 x 204 x 45	153 x 236 x 50			25	7,00 kg
E	P13	P13 case	313	763	71 x 215 x 50	28 x 250 x 56			49	10,90 kg
F	USB	Blister case	345	80	70 x 72 x 16	76 x 104 x 28	3 side		25	4,50 kg
	LAM01	LAM 01 case	401	207	101 x 114 x 18	111 x 177 x 24			130	16,70 kg
G	VOLT	Volt case	414	145	72 x 72 x 28	80 x 130 x 49			48	3,50 kg
	LAM02	LAM 02 case	411	201	99 x 113 x 18	102 x 145 x 24			48	5,80 kg
H	LAM04	LAM 04 case	410	405	97 x 113 x 37	102 x 145 x 42			24	4,40 kg
	LAM11	LAM 11 case	418	399	98 x 110 x 37	108 x 141 x 44	1 side		20	3,00 kg

Best-sellers

Security levels: See p. 60 See p. 59

Optional alarmed protection : see p.62



PROTECTION CASES

HYGIENE AND BEAUTY

RAZORS AND BLADES

Since razor blades packaging is cardboard, they are easily stealable.

The LAM cases prevent this from happening and efficiently protect them against shoplifting. The LAM 05 and LAM 07 cases are perfect for spindles and rack displays.

Cases that protect the razor itself are also available.



P17:
49mm depth



P17D:
71 mm depth



Mechanical razors

Case: P17 | Shallow
P17D | Deep



PHILIPS & WILKINSON

Official partners



PHILIPS



LAM series: almost identical sizes, different depths



B 4 blades pack
Case: LAM02



C 4, 6 and 8 blades pack
Case: LAM07 - LAM09



D 12 blades pack
Case: LAM05



E Thick pack
Case: LAM06



USUALLY COVERS
75% OF THE
PRESENTATION

USUALLY COVERS
25% OF THE
PRESENTATION

18 mm

32 mm

52 mm

65 mm

← Thinner

Deeper →

LAM07

LAM05



The LAM 05 and LAM 07 cases are designed to fit in drawer racks.



PROTECTION CASES

HYGIENE AND BEAUTY

TOOTHBRUSH AND LENSES

Toothbrushes and single-use objects are increasingly targeted by shoplifter.



F

Contact lenses
Case: P28



G

Electrical toothbrush
Case: P29 | Tall and thin
P13 | Wider

BEAUTY EQUIPMENTS (FACE AND BODY)

Our selection of larger cases to protect electrical razors, epilators, clippers, etc.



H



Hygiene equipment

Case: P22 | 20 x 20 x 9 cm
P27 | Higher and deeper
P14 | Large format
P14D | Large and deeper
Alternative : Spider et net spider

	FORS Reference	Product Name	Code on the case	Volume (cm ³)	Internal size (mm) W x H x D	External size (mm) W x H x D	Blister Slot	Security Levels	Packing List	Package Weight
A	P17	P17 case	317*	970	101 x 196 x 49	113 x 228 x 55	1 side		49	12,10 kg
	P17D	Double P17 case	317*	1 392	100 x 196 x 71	113 x 228 x 71	1 side		25	6,80 kg
B	LAM02	LAM 02 case	411	201	99 x 113 x 18	102 x 145 x 24			48	5,80 kg
C	LAM07	LAM 07 case	416*	286	99 x 111 x 26	102 x 145 x 32			48	5,10 kg
	LAM09	LAM 09 case	415	294	99 x 110 x 27	108 x 141 x 32			40	5,20 kg
D	LAM05	LAM 05 case	412*	495	96 x 112 x 46	102 x 145 x 52			30	4,80 kg
E	LAM06	LAM 06 case	413	705	96 x 113 x 65	101 x 144 x 71			24	4,40 kg
F	P28	P28 case	330	196	144 x 80 x 17	153 x 85 x 23			48	3,50 kg
G	P13	P13 case	313	763	71 x 215 x 50	28 x 250 x 56			49	10,90 kg
	P29	P29 case	335	432	58 x 219 x 34	69 x 254 x 40			28	4,40 kg
H	P14	P14 case	314	7 353	230 x 296 x 108	242 x 331 x 115			5	5,10 kg
	P14D	Double P14 case	334	13 787	227 x 292 x 208	242 x 331 x 216			2	2,80 kg
	P22	P22 case	322	3 600	200 x 200 x 90	210 x 230 x 97			10	6,50 kg
	P27	P27 case	327	5 159	198 x 258 x 101	212 x 298 x 106			6	5,20 kg

Best-sellers

Available security levels: see p.60

Optional alarmed protection: see p.62



PROTECTION CASES

HYGIENE AND BEAUTY

THE 2D CASES SERIES

Our cases adjustable in height allow to adapt to perfumes and cosmetics. They valorize the product.



i 2 heights - 3 plate sizes

	<p>A Short - Small plate M1010</p>	<p>B Short - Medium plate M1020</p>	<p>C Short - Large plate M1030</p>
	<p>D Tall - Small plate M2010</p>	<p>E Tall - Medium plate M2020</p>	<p>F Tall - Large plate M2030</p>



PROTECTION CASES

HYGIENE AND BEAUTY

COS 1 & 2 CASES

Our cases adjustable in height allow to adapt to perfumes and cosmetics.

They valorize the product.



G
Cosmetics
COS1 | 45x21 mm base

Adjustable height

95 mm
↕
160 mm



H
Wider cosmetics
COS2 | 59x35 mm base

i

FORSTAG
INNOVATIVE SOLUTIONS

The Forstag Trad can also protect your cosmetics presented under blister with a higher security level.

For more information, see p. 44.

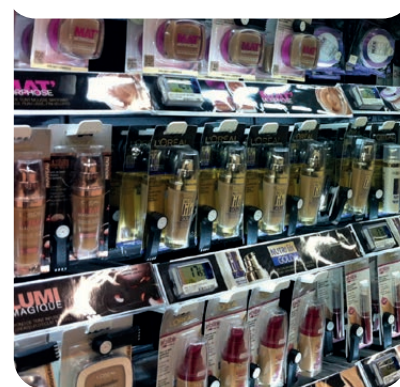

COS 5 CASE

The new COS 5 case and its slick design will be perfect to present your cosmetic creams. It was designed to protect all your presentation.



I
Face care cream
COS5 | 7cm cube

i

Stackable



	FORS Reference	Product Name	Code on the case	Volume (cm ³)	Internal size (mm) W x H x D	External size (mm) W x H x D	Blister Slot	Security Levels	Packing List	Package Weight
A	M1010	Small 2D short adjustable case	M1010	460	74x108 à 135x46	81 x 148 x 79		🔒🔒🔒🔒	48	8,90 kg
B	M1020	Medium 2D short adjustable case	M1020	692	95x110 à 130x56	101 x 148 x 88		🔒🔒🔒🔒	48	10,10 kg
C	M1030	Large 2D short adjustable case	M1030	957	116x105 à 125x66	120x148x98		🔒🔒🔒🔒	24	6,30 kg
D	M2010	Small 2D tall adjustable case	M2010	572	74x135 à 168x46	81 x 184 x 78		🔒🔒🔒🔒	48	9,60 kg
E	M2020	Medium 2D tall adjustable case	M2020	862	95x135 à 162x56	101 x 175 x 88		🔒🔒🔒🔒	48	10,30 kg
F	M2030	Large 2D tall adjustable case	M2030	1 225	116x135 à 160x66	121 x 175 x 98		🔒🔒🔒🔒	24	6,60 kg
G	COS1	COS 1 adjustable case	451	89 à 151	45x95 à 160x21	57 x 123 à 189x45		🔒🔒🔒🔒	70	9,10 kg
H	COS2	COS 2 adjustable case	452	196 à 330	59x95 à 160x35	71 x 127 à 188x59		🔒🔒🔒🔒	40	6,80 kg
I	COS5	COS 5 case	501	352	70x70x72	85x94x94		🔒🔒🔒🔒	80	10,00 kg

● Best-sellers

Security levels: 🔒🔒🔒🔒 See p. 60

🔒🔒🔒🔒 See p. 59

🔒🔒🔒🔒 Optional alarmed protection : see p.62



PROTECTION CASES

TECHNICAL SPECIFICITIES

FORS Reference	Product Name	Code on the case	Volume (cm ³)	Internal size (mm) WxHxD	External size (mm) WxHxD	Blister Slot	Security Levels	Packing List	Package Weight
USB	Blister case	345	80	70x72x16	76x104x28	3 side		25	4,50 kg
VOLT	Volt case	414	145	72x72x28	80x130x49			48	3,50 kg
PRINT	Printer case	207	1 704	183x133x70	192x205x76			26	8,50 kg
C3DTEL	3D Tel case	339	3 988	233x163x105	246x220x109			7	4,50 kg
WIN8	Windows 8 case	342	444	149x149x20	157,5x181x27			20	3,70 kg
CDP	CD full case	106	285	144x132x15	153x163x21			84	14,60 kg
CD3	CD 3 case	104	213	141x126x12	154x145x16			50	3,50 kg
DVDL	DVD light case	119	475	144x194x17	150x228x21			50	9,10 kg
DVDP	DVD full case	111	558	143x195x20	153x230x25			65	15,60 kg
DVD2	Double DVD case	113	1 313	143x204x45	153x236x50			25	7,00 kg
DVHD	Blu-Ray case	117A	430	139x172x18	153x230x23			65	15,40 kg
DVHD3	Triple Blu-Ray case	117B	1 071	137x170x46	149x208x51			30	8,00 kg
DSJL	Game light case	337	375	142x132x20	151x166x27			20	3,80 kg
XBONE	XBOX ONE game case	343	451	138x172x19	148x231x24			55	13,10 kg
XB360	XBOX 360 game case	213	613	143x195x22	154x250x29			50	14,00 kg
PSP1	PSP game case 1	327abc	355	105x188x18	120x285x28			75	18,00 kg
PSP2	PSP game case 2	328	671	105x188x34	120x285x42			63	15,20 kg
PS3	PS3 game case	333	477	138x173x20	148x240x32			50	13,80 kg
PS4	PS4 game case	344	458	140x172x19	148x24x24			50	13,20 kg
PSVITA	PS Vita game case	341A	250	109x135x17	148x240x32			50	8,70 kg
SW1	Switch game case	346	346	175x110x18	205x118x22			20	3,20 kg
WIIU	Wii U game case	332	534	139x192x20	147x252x27			50	13,30 kg
WII	Wii game case	332	534	139x192x20	147x252x27			50	13,30 kg
DSJ	DS game case	325	399	144x132x21	153x163x29			20	3,10 kg
DSC	DS console case	326	2 411	224x156x69	234x190x76			14	6,30 kg
DSI	DSi console case	336	1 785	257x124x56	264x185x64			17	6,30 kg
C3DS	3DS console case	339	3 988	233x163x105	246x220x109			7	4,50 kg
3DSXL	3DS XL console case	342	1 516	190x133x60	204x172x65			16	5,40 kg
PSPC	PSP console case	329	4 074	236x137x126	258x178x131			9	6,20 kg
CDR	PS Vita console case	112	4 094	285x228x63	292x258x68			10	6,70 kg
M1010	Small 2D short adjustable case	M1010	460	74x108 à 135x46	81x148x79			48	8,90 kg
M2010	Small 2D tall adjustable case	M2010	572	74x135 à 168x46	81x184x78			48	9,60 kg
M1020	Medium 2D short adjustable case	M1020	692	95x110 à 130x56	101x148x88			48	10,10 kg
M2020	Medium 2D tall adjustable case	M2020	862	95x135 à 162x56	101x175x88			48	10,30 kg
M1030	Large 2D short adjustable case	M1030	957	116x105 à 125x66	120x148x98			24	6,30 kg
M2030	Large 2D tall adjustable case	M2030	1 225	116x135 à 160x66	121x175x98			24	6,60 kg
COS1	COS 1 adjustable case	451	89 à 151	45x95 à 160x21	57x123 à 189x45			70	9,10 kg

Security levels: See p. 60

See p. 59

Optional alarmed protection: see p.62



PROTECTION CASES

TECHNICAL SPECIFICITIES

FORS Reference	Product Name	Code on the case	Volume (cm ³)	Internal size (mm) WxHxD	External size (mm) WxHxD	Blister Slot	Security Levels	Packing List	Package Weight
COS2	COS 2 adjustable case	452	196 à 330	59x95 à 160x35	71x127 à 188x59			40	6,80 kg
COS5	COS 5 case	501	352	70x70x72	85x94x94			80	10,00 kg
LAM01	LAM 01 case	401	207	101x114x18	111x177x24			130	16,70 kg
LAM02	LAM 02 case	411	201	99x113x18	102x145x24			48	5,80 kg
LAM03	LAM 03 case	409	288	98x113x26	102x145x31			48	6,20 kg
LAM04	LAM 04 case	410	405	97x113x37	102x145x42			24	4,40 kg
LAM05	LAM 05 case	412*	495	96x112x46	102x145x52			30	4,80 kg
LAM06	LAM 06 case	413	705	96x113x65	101x144x71			24	4,40 kg
LAM07	LAM 07 case	416*	286	99x111x26	102x145x32			48	5,10 kg
LAM09	LAM 09 case	415	294	99x110x27	108x141x32			40	5,20 kg
LAM10	LAM 10 case	417	294	99x110x27	108x141x32	1 side		40	5,20 kg
LAM11	LAM 11 case	418	399	98x110x37	108x141x44	1 side		20	3,00 kg
P01	P01 case	301	154	100x67x23	107x100x29			48	4,70 kg
P03	P03 case	303	160	104x81x19	113x114x29			48	4,00 kg
P04	P04 case	304	406	106x81x50	102x145x42			24	4,40 kg
P05	P05 case	305	161	100x67x24	108x100x35			48	4,60 kg
P06	P06 case	306	468	128x122x30	137x155x38	1 side		48	9,40 kg
P07	P07 case	307	730	149x71x69	156x101x81			40	8,90 kg
P08	P08 case	308	847	128x135x49	139x166x60	1 side		40	9,90 kg
P10	P10 case	310	1 340	143x218x43	153x258x49	1 side		25	9,20 kg
P11	P11 case	311	1 174	135x189x46	145x235x53			25	8,30 kg
P12	P12 case	309	701	99x118x60	110x151x71	1 side		40	8,70 kg
P13	P13 case	313	763	71x215x50	28x250x56			49	10,90 kg
P14	P14 case	314	7 353	230x296x108	242x331x115			5	5,10 kg
P14D	Double P14 case	334	13 787	227x292x208	242x331x216			2	2,80 kg
P15	P15 case	315	10 249	227x215x210	240x260x215			2	2,30 kg
P17	P17 case	317*	970	101x196x49	113x228x55	1 side		49	12,10 kg
P17D	Double P17 case	317*	1 392	100x196x71	113x228x71	1 side		25	6,80 kg
P20	P20 case	320	1 522	118x300x43	126x333x51			24	10,10 kg
P22	P22 case	322	3 600	200x200x90	210x230x97			10	6,50 kg
P25	P25 case	325*	2 600	200x260x50	212x297x58			12	7,20 kg
P26	P26 case	326	3 626	200x259x70	221x298x78			10	7,40 kg
P27	P27 case	327	5 159	198x258x101	212x298x106			6	5,20 kg
P28	P28 case	330	196	144x80x17	153x85x23			48	3,50 kg
P29	P29 case	335	432	58x219x34	69x254x40			28	4,40 kg
T01	T01 case	347A	563	112x201x25	120x234x30			50	9,95 kg
T03	T03 case	348	2 831	150x222x85	154x256x90			14	5,56 kg

Security levels: See p. 60

See p. 59

Optional alarmed protection: see p.62



PROTECTION CASES

PRACTICAL GUIDE : LIFE-SIZE

HOW TO CHOOSE THE RIGHT CASE ?

The following table presents the main cases (without console cases) at the 1/1 scale.

Place the product you need to protect on the table so as to easily find the best fitted case.

Then check the depth of your product's packaging with the different cases offered.

Internal dimensions life-size



Height in cm

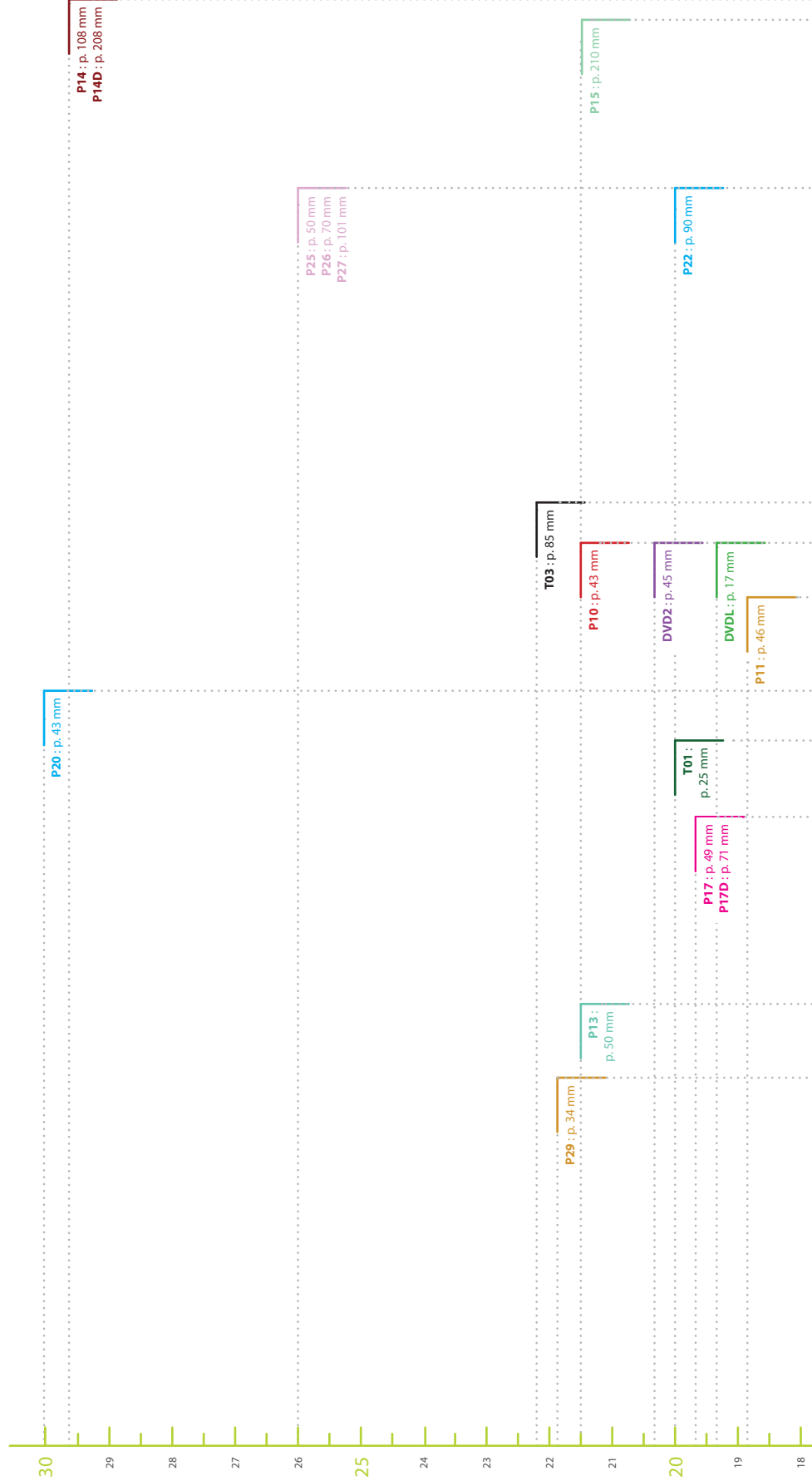



PROTECTION CASES

PRACTICAL GUIDE : LIFE-SIZE

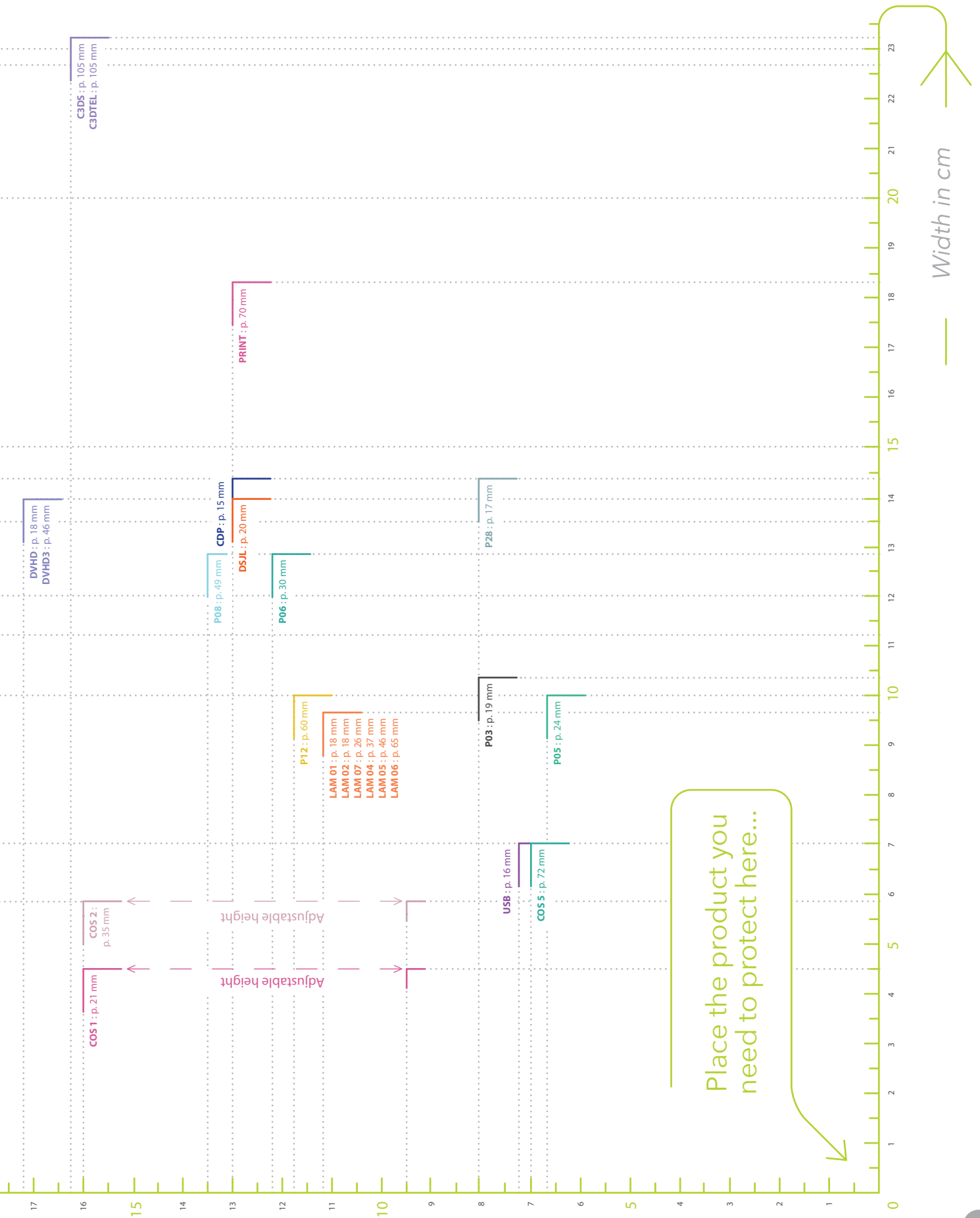

TOUCH DISPLAY AND LISTENING STATIONS





- Alarm 2 series :
 - General presentation 90
 - Brackets and alarm cables 92
 - Locking cables and spindles 93
 - Secured plates 94
 - Charging accessories 95
- Loop 2 et Splitter 2 series 96
- Watch series 97
- Tools 98
- Mechanical protections 99
- Listening stations 100
- Customized listening stations 102





TOUCH DISPLAY

ALARM 2 SERIES

ALARM 2 SERIES

Compact model, very practical



NEW INTELLIGENCE

A revolution in security.

This unrivalled product will secure any device in any possible environment.

The Alarm 2 series is the optimal solution to allow the self-service display of **smartphones, tablets, cameras, photo cameras and computer.**

This technology is equipped with a security mechanism with a tetrahedronal key that adapts to all security accessories.

Automatic engagement secured sensor.

USB port for charging cable.

Tetrahedronal security mechanism.

Anodized aluminium coating and polished stainless steel.





TOUCH DISPLAY

ALARM 2 SERIES

COMPACT MODEL, VERY PRACTICAL

This technology possesses the most intelligent card to this day.

The micro controller manages both sensors, the charging system, the optional emergency battery as well as the remote control.

The alarm was redesigned so it can be heard in any environment.

The base is lit with one LED lamp to offer a better light.

White LED light

Fast charging

Powerful audio alarm



A SOLUTION ADAPTED TO DIFFERENT DEVICES

Simple to install and to use.
Easy for the staff that re-arrange the merchandise.

Speakers



Smartphones



Tablets



Computers



Caméras





TOUCH DISPLAY

BRACKETS AND ALARM CABLES

THE CHOICE OF SHAPE AND INCLINATION

Our new brackets range allows the Alarm 2 series to change shape without substituting the full solution for a set-up on a furniture or on the wall.



i

Technical features

Smartphones mounting bracket

- Chromed plastic
- Height 40 mm
- Diameter 44 mm
- 3M adhesive and screw fixation.

Tablets mounting bracket

- Anodized aluminium
- Height 54 mm
- Diameter 63 mm
- 3M adhesive and screw fixation

A Smartphones mounting bracket
JSD-200-A-Y | Chromed plastic

B Tablets mounting bracket
JSD-204-A-Y | Anodized aluminium

THE RIGHT CABLE FOR THE RIGHT USE

Two cable options adapted to your environment.



C  2 HS alarm with steel cable
JHS-101-A-Y | 300 mm cable



D  2 MS alarm with spiraled cable
JMS-101-A-Y | 200 to 900 mm cable

	FORS Reference	Product Name	Dimensions (mm)	Material	LED	Package List	Package Weight
A	JSD-200-A-Y	Smartphones mounting bracket	H 40 x Ø 44	Chromed plastic		unit	0,07 kg
B	JSD-204-A-Y	Tablets mounting bracket	H 54 x Ø 63	Anodized aluminium		unit	0,07 kg
C	JHS-101-A-Y	2 HS alarm with steel cable	Ø 40 – Cable 300	Anodized aluminium / Polished stainless steel	White	unit	0,50 kg
D	JMS-101-A-Y	2 HS alarm with spiraled cable	Ø 40 – Cable 200 to 900	Anodized aluminium / Polished stainless steel	White	unit	0,20 kg



TOUCH DISPLAY

CABLES AND LOCKING SPINDLES

With our accessories range, raising up your level of security has never been so easy.

AUDIO LOCK

The 3,5mm patented audio locking mechanism offers maximum security (538LB).

The remodeled lock displays a slick look thanks to its light aluminium

structure, nonetheless very resistant.

It benefits from a 180° pivotal movement that allows to hide the cable.

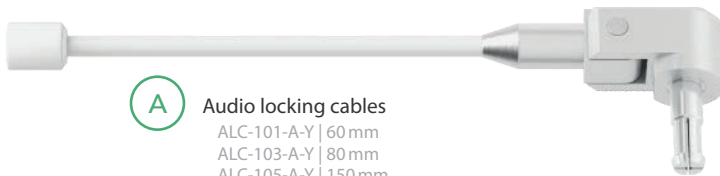

- A** Audio locking cables
- ALC-101-A-Y | 60 mm
 - ALC-103-A-Y | 80 mm
 - ALC-105-A-Y | 150 mm
 - ALC-107-A-Y | 190 mm
 - ALC-109-A-Y | 350 mm



LOCKING SPINDLES

They were created from a unique aluminium piece to make them even thinner, light and secured.

The surface is polished with a superior gloss in order to limit its visual aspect.

We have integrated our tetrahedral key to safely control the arm locks in order to obtain a perfect fit.

Three version are available for smartphones, phablets and tablets.

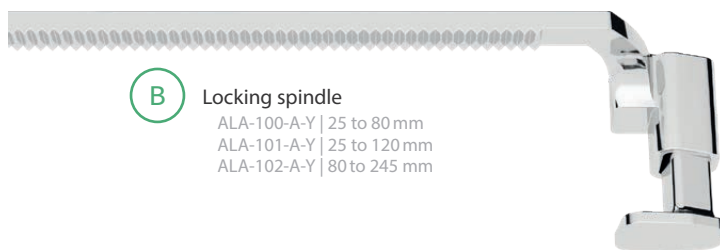

- B** Locking spindle
- ALA-100-A-Y | 25 to 80 mm
 - ALA-101-A-Y | 25 to 120 mm
 - ALA-102-A-Y | 80 to 245 mm



	FORS Reference	Product Name	Dimensions (mm)	Protected Products	Package List	Package Weight
A	ALC-101-A-Y	Audio locking cable	Length : 60 mm	4 to 5 inches smartphones	unit	0,07 kg
	ALC-103-A-Y	Audio locking cable	Length : 80 mm	5,1 to 6,5 inches smartphones	unit	0,07 kg
	ALC-105-A-Y	Audio locking cable	Length : 150 mm	7 to 10 inches tablets	unit	0,2 kg
	ALC-107-A-Y	Audio locking cable	Length : 190 mm	10,1 to 13 inches tablets	unit	0,5 kg
	ALC-109-A-Y	Audio locking cable	Length : 350 mm	Computers	unit	0,5 kg
B	ALA-100-A-Y	Locking spindle	Adjustable : 25 to 80 mm	4 to 5 inches smartphones	unit	0,5 kg
	ALA-101-A-Y	Locking spindle	Adjustable : 25 to 120 mm	5,1 to 6,5 inches smartphones	unit	0,5 kg
	ALA-102-A-Y	Locking spindle	Adjustable : 80 to 245 mm	Tablets	unit	0,5 kg



TOUCH DISPLAY

SECURED PLATES

DIFFERENT SECURED PLATES ACCORDING TO THE DEVICE

Stick Alarm 2 to any flat surface to set it up.

This plaque adapts to all devices to secure it and allows to integrate the audio locking-cable.



A Standard secured plate
ASP-100-A-Y | Audio locking

This plate was specifically conceived to be integrated to devices needing a screw fixation such as cameras, numerical cameras....

It also allows integration with the audio locking-cable.



B Secured plaque with screw
ACP-101-A-Y | Screw & audio locking

This plaque was specifically conceived for the use of the spindle-locks.

It can be combined with the use of an audio locking cable.



C Secured plaque for spindles
ALP-100-A-Y | Spindle locking

	FORS Reference	Product Name	Dimensions (mm)	Material	Package List	Package Weight
A	ASP-100-A-Y	Standard secured plate	Ø 41	Aluminium	Unit	0,02 kg
B	ACP-101-A-Y	Secured plaque with screw	Ø 40	Aluminium	Unit	0,02 kg
C	ALP-100-A-Y	Secured plaque for spindles locking	Ø 41	Aluminium	Unit	0,06 kg



TOUCH DISPLAY

CHARGING DEVICES

CHARGE YOUR DEVICES WITH SECURED CABLES

Our alarm-equipped charging cables can be plugged easily, allowing to charge any 5 v device.

The new conception creates a neat and uniform display for all types of device.

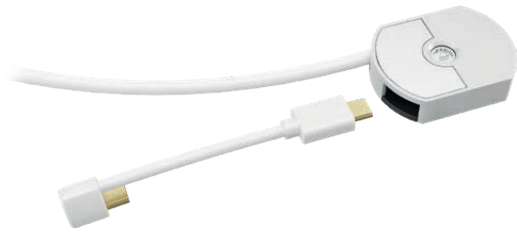

A Micro-USB charging U cable

ACA-121-A-Y | 50 mm
ACA-123-A-Y | 80 mm
ACA-125-A-Y | 150 mm



B USB C charging U cable

ACA-221-A-Y | 50 mm
ACA-223-A-Y | 80 mm
ACA-225-A-Y | 150 mm



C Apple charging U cable

ACA-311-A-Y | 50 mm
ACA-313-A-Y | 80 mm
ACA-315-A-Y | 150 mm



CHOOSE YOUR GENERAL POWER LEVEL

Connect to Alarm 2 to charge your display device.



D General power cable APW-109-B-Y | 0,5 Amp.



E High power cable APW-108-B-Y | 2 Amp.

	FORS Reference	Product Name	Dimensions (mm)	Protected Products	Package List	Package Weight
A	ACA-121-A-Y	Micro USB charging U cable	Length : 50 mm	4 to 5 inches smartphones	Unit	0,01 kg
	ACA-123-A-Y	Micro USB charging U cable	Length : 80 mm	5,1 to 6,5 inches smartphones	Unit	0,01 kg
	ACA-125-A-Y	Micro USB charging U cable	Length : 150 mm	Tablets	Unit	0,01 kg
B	ACA-221-A-Y	Type C charging U cable	Length : 50 mm	4 to 5 inches smartphones	Unit	0,01 kg
	ACA-223-A-Y	Type C charging U cable	Length : 80 mm	5,1 to 6,5 inches smartphones	Unit	0,01 kg
	ACA-225-A-Y	Type C charging U cable	Length : 150 mm	Tablets	Unit	0,01 kg
C	ACA-311-A-Y	Apple charging U cable	Length : 50 mm	4 to 5 inches smartphones	Unit	0,01 kg
	ACA-313-A-Y	Apple charging U cable	Length : 80 mm	5,1 to 6,5 inches smartphones	Unit	0,01 kg
	ACA-315-A-Y	Apple charging U cable	Length : 150 mm	Tablets	Unit	0,01 kg
D	APW-109-B-Y	General power cable - 0,5 Amp	Length : 1500 mm		Unit	0,04 kg
E	APW-108-B-Y	High power general power cable - 2 Amp	Length : 1500 mm		Unit	0,04 kg



TOUCH DISPLAY

LOOP AND SPLITTER SERIES

Loop 2 series

Splitter 2 series



STRONG, ELEGANT, DISCREET AND POLYVALENT

At the heart of these two series is the brand new **adjustable pendant**.

Easily modify the buckle circumference so it precisely matches the size of the device to protect.

When closed, the pendant firmly tightens the cable to prevent any movement.

The **Loop 2** aeronautic-quality steel cable can resist a breaking force up to 295 kg. It is also protected by its reinforced-steel sheath.

The **Splitter 2** is based on the same principle, with a power cable shielded by a steel sheath and an **alarm** that goes on if it is severed or unplugged.



A Loop 2 cable
JLP-200-A-Y | With clip



B Double Loop 2 cable
JLP-220-A-Y | Double pendant

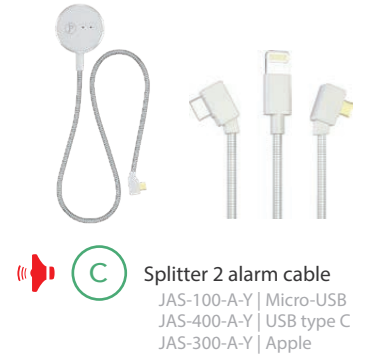
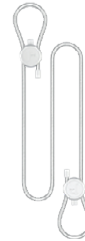

C Splitter 2 alarm cable
JAS-100-A-Y | Micro-USB
JAS-400-A-Y | USB type C
JAS-300-A-Y | Apple

Mounting options



Self-adhesive



Buckle



Screw



These series are polyvalent and modular, compatible with each other as well as with the audio-locking cable (see p.93).



SECURE THE IMPOSSIBLE

Loop 2 and Splitter 2 can secure all forms and sizes. They offer an excellent protection even of big devices.



D Pendant lock
ACP-103-A-Y | Adjustable

	FORS Reference	Product Name	Dimensions (mm)	Package List	Package Weight
A	JLP-200-A-Y	Loop 2 cable	1000 mm	Unit	0,25 kg
B	JLP-220-A-Y	Double Loop 2 cable	1000 mm	Unit	0,25 kg
C	JAS-100-A-Y	Micro-USB Splitter 2 cable	1000 mm	Unit	0,20 kg
	JAS-400-A-Y	USB type C Splitter 2 cable	1000 mm	Unit	0,20 kg
	JAS-300-A-Y	Apple Splitter 2 cable	1000 mm	Unit	0,20 kg
D	ACP-103-A-Y	Pendant lock	Ø 40	Unit	0,05 kg



TOUCH DISPLAY

WATCH SERIES



Watch series

ELEGANT DESIGN

Elegant design that does not cover the watch surface



ONE SIZE ONLY

Secure a large range of devices without needing any support or spindle



High-security solution



Compatible with OEM connector



Alarm-equipped solution with Micro-USB connection

The mounting bracket allows for a mechanical security for which a 1Ms alarm can be added in order to increase security level.



A General power cable
APW-109-B-Y | 0,5 Amp.

B Mounting bracket for watch
APT-210-A-Y | 200 to 900 mm cable

C  1 MS Alarm with spiraled cable
JAC-101-A-Y | 200 to 900 mm cable

	FORS Reference	Product Name	Dimensions (mm)	Material	Package List	Package Weight
A	APW-109-B-Y	General power cable - 0,5 Amp	1500 mm		Unit	0,04 kg
B	APT-210-A-Y	Mounting bracket for watch	Ø 50 – H 75	Aluminium	Unit	0,15 kg
C	JAC-101-A-Y	1 Ms Alarm with spiraled cable	Ø 50 – Câble 200 à 900	Anodized aluminium / Polished stainless steel	Unit	0,12 kg



TOUCH DISPLAY

TOOLS

SIMPLY SAFE

The new smart key system has a unique protection with interchangeable key codes.

Eliminate costs linked to keys management, in charging and programming.

A 2 in 1 withdrawal tool simplifies the change of the device to protect. Your unique tool insures a simple and safe maintenance and re-merchandising.



A Deactivation key
APT-101-A-Y | Smart key



B Tetrahedral security key
APT-201-A-Y



C Withdrawal tool
APT-200-A-Y

COMFORTABLE FOR THE USER

Allows to feel the real weight of the device without the weight of security.



	FORS Reference	Product Name	Dimensions (mm)	Material	Package List	Package Weight
A	APT-101-A-Y	Deactivation key	40 x 13 x 05	Plastic	Unit	0,05 kg
B	APT-201-A-Y	Tetrahedral security key	65 x 25 x 04	Aluminium	Unit	0,05 kg
C	APT-200-A-Y	Withdrawal tool	180 x 30 x 50	Plastic	Unit	0,35 kg



TOUCH DISPLAY

MECHANICAL PROTECTIONS

MECHANICAL PROTECTION FOR LAPTOP

ProtecOrdi allows to protect laptop computers.

The adjustable arms offer a protection for all models on the market. The set-up up can be done directly by the shop staff.



Protection breaks

Lock

17 to 41 cm adjustable arms

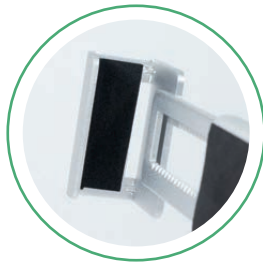

- Fast and simple set-up
- Aluminium
- Mechanical protection

A Computer protection
PROTECORDI | Aluminium

MECHANICAL PROTECTION FOR TABLETS

Built in metal, the ProtecTab is the most secure solution to mechanically protect your tablets in-store while letting your products in display.

The client can rotate the tablet from portrait to landscape mode thanks to its rotation axis.



B 8 to 12" tablet protection
CTAB-COR1 | From 21 to 31 cm diagonal



C 12 to 16" tablet protection
CTAB-COR2 | From 30 to 41 cm diagonal



D Base for tablet protection
CTAB-S30

- Fast and simple set-up
- 2 adjustable arms designs
- Free 90° rotation of the product
- Great robustness

	FORS Reference	Product Name	Protected Products	Package List	Package Weight
A	PROTECORDI	Adjustable aluminium ProtecOrdi	From 17 to 41 cm wide computer	1	16,7 kg
B	CTAB-COR1	ProtecTab small model	From 21 to 31 cm diagonal tablet	1	3,5 kg
C	CTAB-COR2	ProtecTab large model	From 30 to 41 cm diagonal tablet	1	5,8 kg
D	CTAB-S30	ProtecTab base		1	4,4 kg



LISTENING STATIONS

LISTENING STATIONS

LISTENING STATIONS

For more than 30 years, Fors has been developing listening stations for specialized stores, libraries and media libraries...

Our reputation was built on the robustness of our products and on our Fors Prestige anti-vandalism headset, designed to endure uninterrupted use in a public space.

i *Sturdiness*

- Anti-corrosion paint
- Anti-vandalism Fors Prestige headset
- Protections plates for displayed CDs
- Anti-vandal buttons and sheath

CD LISTENING STATION

- 1 to 3 CD set-up: TOP promotion / new items in the catalogue.
- Minimum bulk.
- 2 min limitation for each track.

i *Easy to use*

- Automatic play as the headset is taken off its support, thanks to the photoelectric cell, and a simple pressure on the CD cover.
- Possibility to set-up track forward / back and sound.
- Luminous display of the soundtrack number.
- Fast CD change for the store staff.

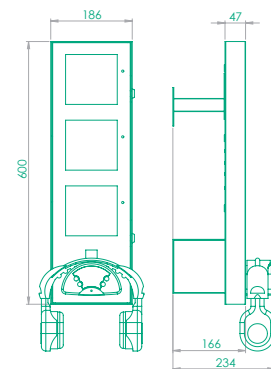

A Multi listening post (3 CDs)
PE3CD

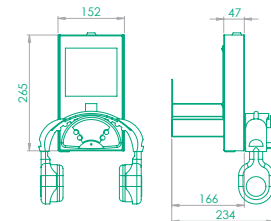

B Monolux listening post (1 CD)
PE1CD

MP3 LISTENING STATION

- MP3 files stored on a memory stick (provided). Minimum bulk.
- Play/Pause buttons (no automatic play when headset are taken off the support).
- Two functions buttons:
Short pressure: track change.
Long pressure: volume adjustment.
- Mounting of the listening station by screw (not provided), directly on the table or counter.

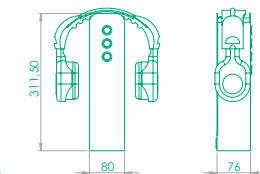

C MP3 listening post
PEMP3

ON DEMAND LISTENING STATION

This listening station allows the client to listen to all CDs at the counter, with the help of staff.

- Track change and volume adjustment is made by the user.

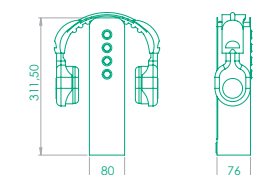

D On demand listening post
BEA



LISTENING STATIONS

LISTENING STATIONS

FORS PRESTIGE HEADSET

The Prestige headset is patented and was designed in very durable and "anti-vandalism" materials and sheath.

The sanitary cushions are interchangeable (sold by pair).

This headset is ideal for use in high affluence areas (stores, libraries, museums).



E Prestige headset
CASQUE-PRE



F Replacement cushions
CASQUE-COUSS



Anti-vandalism reinforced plastic



Stainless steel cable (1 m)

PARABOLIC SPEAKER

Listening comfort and sound quality

- Good sound quality
- No need for a headset: no sanitary issue, as could appear with time of use
- Sound isolation under the parabola and absolute movement freedom
- Customized listening (1 to 2 persons) with no sound disturbance on the surrounding environment.
- Integrated amplifier in the dome. Jack plug-in (5m cable provided).

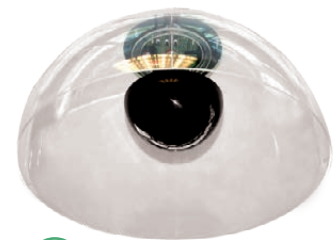

G Parabolic speakers
DOME

	FORS Reference	Product Name	Dimensions (mm) WxHxD	Package List	Package Weight
A	PE3CD	Multi listening station 3 CD	186x600x234	Unit	9,00 kg
B	PE1CD	Monolux listening station 1 CD	152x265x234	Unit	3,20 kg
C	PEMP3	MP3 listening station	80x311,5x76	Unit	2,60 kg
D	BEA	On demand listening station	80x311,5x76	Unit	5,20 kg
E	CASQUE-PRE1	Prestige headset		Unit	0,60 kg
F	CASQUE-COUSS	Cushions for Prestige headset		One pair	0,05 kg
G	DOME	Parabolic speakers	Ø 510 – H 240	Unit	3,00 kg



LISTENING STATIONS

CUSTOMIZED LISTENING STATIONS

CUSTOMIZED LISTENING STATIONS

For more than 30 years, Fors has been developing listening stations for specialized stores.

As a manufacturer, we have developed the application part for connected tablets as well as the external structure, following our clients' requirement specifications.

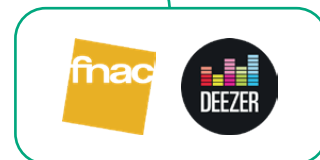

Deezer station



Bracket with edge



Bracket with pendant



Custom-made integration

You too, develop just the product that you need with Fors !

For all your projects

Contact our sales department at :

00 331 4177 6200

and by email : contact.commercial@fors.fr

Our team will study the best set-up with you to guarantee maximum security for your products.



Our wide network of certified technicians ensures your installations maintenance.



Installation in mainland France.



**ANTI-THEFT
SOLUTIONS**

Design and layout:
Lx Design
acottin@me.com



FORS

Anti-Theft Solutions

ADDRESS

Zac des Nations
295, rue du Professeur Milliez
94500 Champigny sur Marne
France

CONTACT

Phone: +33(0)1 41 77 62 00
Fax: +33(0)1 41 77 62 40
Email: contact.commercial@fors.fr
Website: www.fors.fr